

HO Pressure Switches

INSTALLATION AND OPERATING INSTRUCTIONS

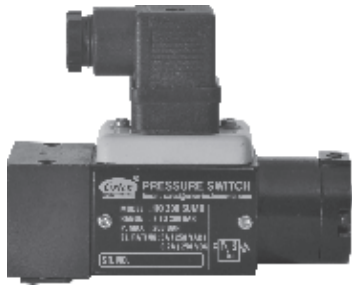

**PRESSURE SWITCHES
PRESSURE DIFFERENCE SWITCHES
VACUUM SWITCHES**
From 1.5 mbar to 600 bar

CONSTRUCTION:

The pressure switch is housed in a die cast aluminium enclosure which conforms to IP65 protection. The pressure capsule of the switch comprises a housing (MS), a seal, and a piston (Alloy Steel). The electrical wiring terminates at a terminal strip to DIN 43650.

PRINCIPLE OF OPERATION:

The pressure in the pressure capsule is converted into force by means of a calibrated piston, which is balanced by a compression spring from above. When the force generated by the pressure in the pressure capsule exceeds/falls beyond the balancing spring force, an electrical element is actuated.

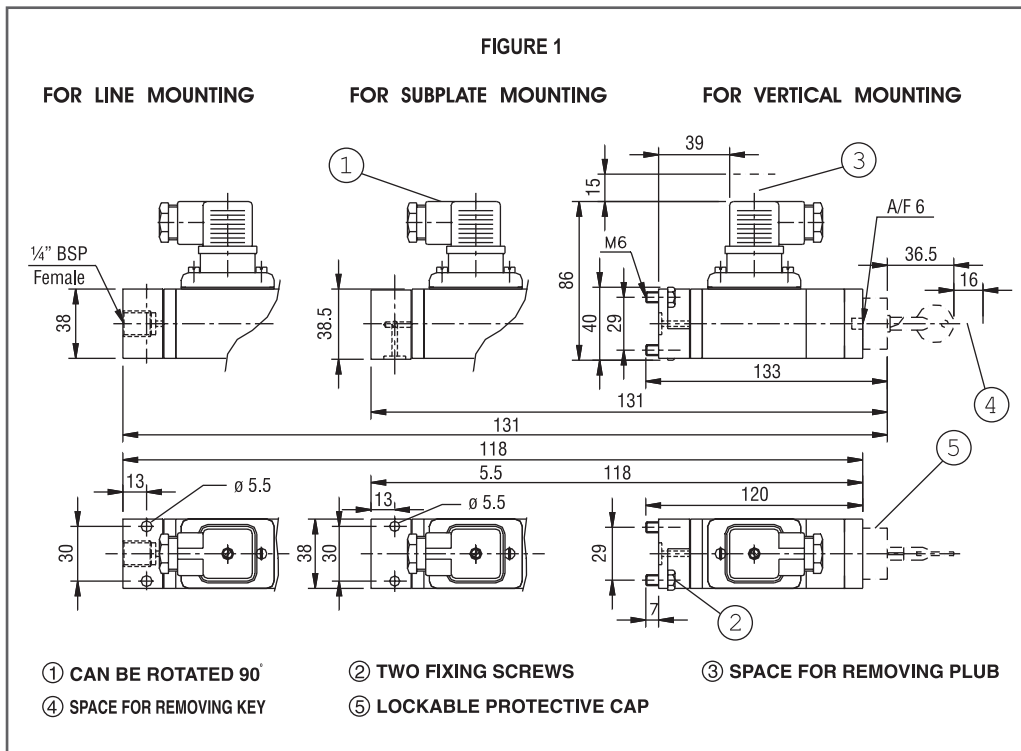

MOUNTING:

Please refer Figure 1. HO model pressure switches can be mounted in any direction. There are three different mounting options.

a) LINE MOUNTING:

1/4" BSP threads are provided for these switches, the switch can be mounted using two M5 bolts of appropriate length. They can also be mounted on the manifold by means of an adaptor for hydraulic applications.

b) SUBPLATE MOUNTING:

The switch can be mounted directly on a manifold by using this arrangement. Use M5 bolts of appropriate length through the mounting holes.

c) VERTICAL STACKING:

This arrangement is provided for using pressure switches in a stack. The switch can be mounted as a vertical element using a proper size sandwich plate.

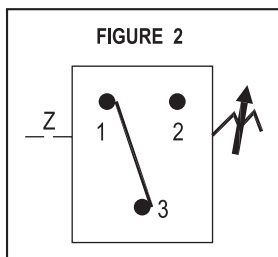

ELECTRICAL CONNECTIONS: (Fig. 2)

HO model pressure switches will generally have only one SPDT microswitch.

Certificate No.: FM72815



Kaustubha Udyog (Orion Instruments)

S. No. 36/1/1, Sinhgad Road, Vadgaon Khurd, Pune 411 041 INDIA

Tel.: +91-(0) 20-24393877

Telefax : +91-(0) 20-24393577 / 25460486

Email : pressure@vsnl.com / info@orion-instruments.com

Website : www.orion-instruments.com

BULLETIN NO. : KA130820

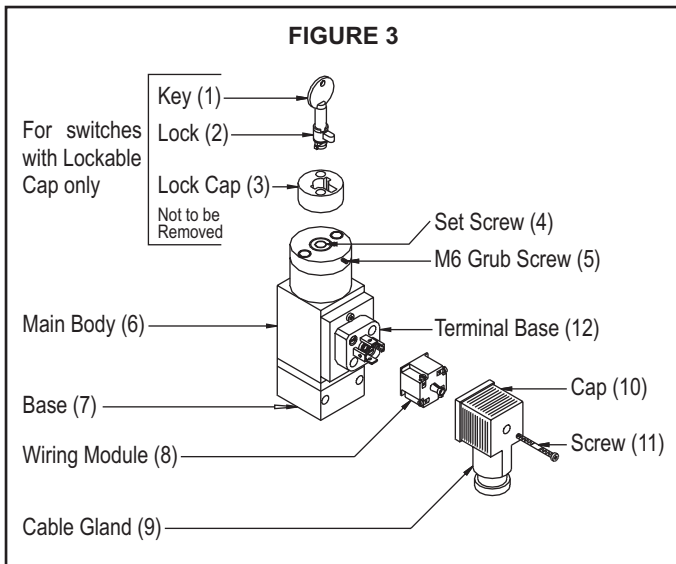

WIRING: (fig. 3)

Connectors to DIN 43650 are provided with every HO model pressure switch.

- a) Remove the screw (11) retaining the cap (10) and wiring module (8).
- b) Remove the cap (10) and wiring module (8).
- c) The cap (10) will have to be separated from the wiring module (8). The wiring terminators are embossed on the wiring module (8). Pass the cable through the cable gland (9) and fit the wires in the screwed ends.
- d) Replace the cap (10) on the module (8), depending on the direction of the cable desired and fit the module (8) on the terminal base (12).
- e) Fit the retaining screw (11) onto the cap (10).

SET POINT ADJUSTMENT HO MODELS:

- 1) Remove the lock (2) (for switches with lockable protective cap)
- 2) Loosen the M6 grub screw (5) on top of set screw (4).
- 3) Turn the set screw (4) to the extreme negative end.
- 4) Apply the desired cutin (lower)/cutout (higher) pressure to the pressure switch.
- 5) Increase the pressure setting by turning the set screw (4) till contacts changeover.
- 6) Some minor adjustment will be required to achieve the exact cutin (lower)/cutout (higher) point which can be checked with the help of a proper pressure measurement device.
- 7) Tighten the grub screw (5) so as to avoid any drift in setpoint.
- 8) Replace the lock (2) and remove the key (1) (for switches with lockable protective cap)

TIP: The pressure switches are factory set at half the setpoint range (unless otherwise specified in a Purchase Order). Step 2 can be omitted if the desired setpoint is more than the factory setting.

TROUBLE SHOOTING TIPS

Generally no problems are observed if the pressure switch selection, wiring and the setpoint is proper. For a pressure switch selection procedure, please consult our sales office.

For properly selected pressure switches, if following symptoms are observed, the likely causes and remedies are as stated below.

SYMPTOM 1: SWITCH DOES NOT OPERATE

- 1) Wiring may not be correct. Check electrical connections to the pressure switch, if they are as per the wiring diagram.
- 2) Pressure does not reach the pressure port.
 - a) Check if the entry to the pressure capsule is blocked by scales or impurities in the process.
 - i) If this is the case, try freeing the blocked path by a blunt tool in case of scales and impurities

DO NOT OPEN THE PRESSURE CAPSULE IN ANY EVENT

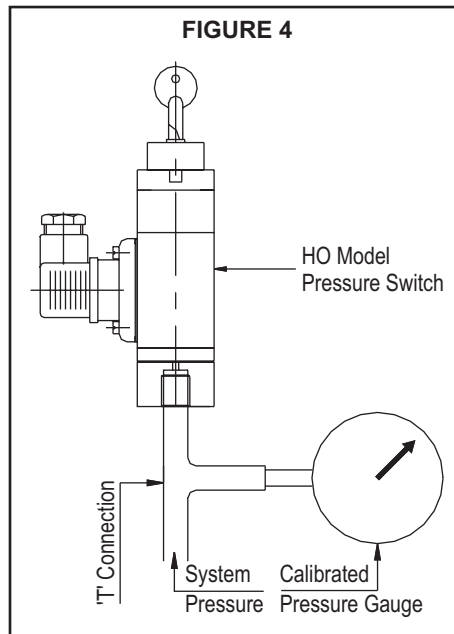

If the cause is none of the above mentioned probabilities, proceed as per the following steps.

- b) Check the system pressure & set point of pressure switch.
 - i) For use of pressure switch for falling setpoints, system pressure has to be greater than the cutout point.
 - ii) For use of pressure switch for rising setpoints, the system pressure may not be reaching/exceeding the cutout point.
 - iii) Use "T" connection & connect calibrated pressure guide to the "T" connection as shown in the figure 4.
 - iv) Adjust the setpoint such that the system pressure is greater than the cut-out point of the pressure switch.
 - v) If the switch still does not operate, remove the pressure switch physically from the system. There should be continuity between terminals 1& 3. If no continuity is observed even after one setscrew rotation, the pressure switch should be returned to the factory.

SYMPTOM 2: SHORT WIRING

Isolate the switch electrically. Check the continuity between terminals and the screws fitted to the body. If no continuity is observed between any of the terminals and the screws fitted to the body, check the short connection elsewhere in the circuit. If continuity is observed, the wires of the pressure switch have internally touched the body, and the switch should be returned to the factory.

SYMPTOM 3: LEAKAGE

In case leakage is observed, the pressure switch has to be returned to the factory without opening the pressure capsule. Check for the following likely causes and use a new switch taking proper precautions.

- 1) System pressure is greater than working pressure: Use an over range protector or a switch with appropriate maximum working pressure.
- 2) Excessive process temperature: Process temperature may exceed maximum allowable temperature, which in turn damages the diaphragms. Use an impulse tubing of proper length for cooling the process temperature. There may be a pressure drop depending on the length of the impulse tube used. Adjust the setpoint of the pressure switch accordingly.

SYMPTOM 4: CHATTERING

- 1) Check the system pressure for surges. Chattering is observed where the system pressure is close to the cutin/cutout point and the surge pressure exceeds the on-off differential. Use a pressure switch with adjustable differential or use surge dampers in your system.
- 2) If there is a relay in the circuit, check the relay is properly plugged in. Chattering may be due to loose contacts. ■