

OEM SWITCHES

SPECIFIER'S GUIDE FOR

PRESSURE SWITCHES

PRESSURE DIFFERENCE SWITCHES



EZ Serisi



Using the section

This section on “How to use this catalogue “ helps you make a logical choice in selecting the best product for a particular application. It allows a user familiar with our product line to locate the exact page the product is listed on. For those not familiar with our products, a logical sequence is given to help the user pick the best product for their need.

By taking a few minutes to familiarise yourself with the catalogue organization, you will find it very easy to locate the product / information you need.

1. The contents page lists the broad outline in which the catalogue is organized, and will help the user familiar with products to select the page on which the product or other useful information is listed.

2. Need Product Selection help ?

Product selection help will start with the “Pictorial Index” on Page 291, where the products are broadly classified. A brief description of each product group , a typical photo of the product within the group and the page number on which it is listed are given.

If the user is not familiar with the products, a product selection guide is provided on pages 294 through 298, where photos for each product and important specifications are given to help determine and select the best product for the application.

By evaluating and comparing these parameters, a logical selection can be made. Turn to the page on which the product information for the selected product is listed, for :

Capsule Construction details

Physical sizes

Special features

Ranges, hysteresis, electrical ratings etc.

Ordering information

The organisation of each of these pages is demonstrated on pages 292 and 293, of this section “How to use this catalogue”.

In many cases, more than one product may work. For the most cost effective solution, compare prices and consider alternatives. Remember, the end cost includes initial product price, plus the installation, plus the service.

3. Need the terminology explained? (see page 330)

Turn to page 330 for the definitions and terminology. This will help you familiarize with the terms used throughout the catalogue.

4. Need information on Accessories? (see page 322)

Turn to page 322 for information on important accessories. These will give information on only important accessories, and information needed, when these are to be supplied with our products.

5. Need selection guidance? (see page 331)

A logical procedure on page 331 will help you to consider most of the important factors when selecting a pressure switch.

6. Need other products ? (see page 332)

Products other than those listed in this catalogue are referenced on these pages. Separate catalogues for these products are available.

Pictorial Index

SC SUBMINIATURE



Page No. 300

SM



Page No. 302

SA



Page No. 304

EZ/EX



Page No. 306

EZ_A/EX_A



Page No. 308

MZ/MX



Page No. 310

MZ_A



Page No. 312

MD

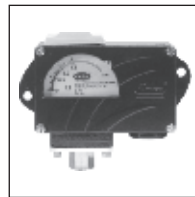

Page No. 314

MD_A

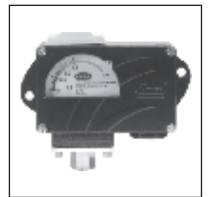

Page No. 316

CF

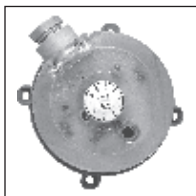

Page No. 318

CS12



Page No. 320

OTHER PRODUCTS

TR



Page No. 332

HOW TO USE this section

Due to the variety in product types and their salient features, catalogue page formats may vary. But generally the following formats are adhered to.

Elements appearing on each page will be:

1. Product family / series - A product family / series will appear on the outside page corner, depending on the left / right hand page, and will be in large bold type.
2. Product section - will appear immediately following the product family / series at top of the page and will be in bold type.
3. Features - will appear next to product description & will enlist only the major attributes.
4. Pressure capsule details - will show the construction of the pressure capsule and all its internal parts. If the process / working medium is variable, the wetted parts will be mentioned in italics. If the wetted parts are unique, the material of construction (MOC) will be mentioned

alongside in brackets. Where the material of construction is not specified, it will vary and the options are to be selected by the user considering the compatibility of the process / working medium. Modifications can be made to suit any particular medium, if the answer for your needs is not in the standard MOC listed. Products for which process / working medium is predefined, pressure capsule details are not provided (e.g as in case of comparison test pump). Pressure capsule details of accessories are not given.

5. Installation drawing - will show the typical installation dimensions of products as they exist in their standard forms. The dimensions are mentioned in millimetres and also in inches to facilitate the user. The dimensions of accessories will have to be added to these to arrive at any particular general arrangement (GA) drawings. The dimensions are approximate and for precise dimensions, where mounting space is restricted, the user may contact the nearest sales office. Installation drawings of only fast moving accessories are given.

1 ● **SM** OEM HIGH RANGE PRESSURE SWITCHES



6 ●



2 ●

7 ●

4 ●

3 ●

4 ●

4 ●

5 ●

302

Pressure Capsule Details

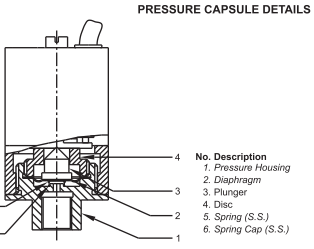

No. Description
1. Pressure Housing
2. Diaphragm
3. Plunger
4. Disc
5. Spring (S.S.)
6. Spring Cap (S.S.)

Note: wetted parts are mentioned in italics.

INSTALLATION DRAWING

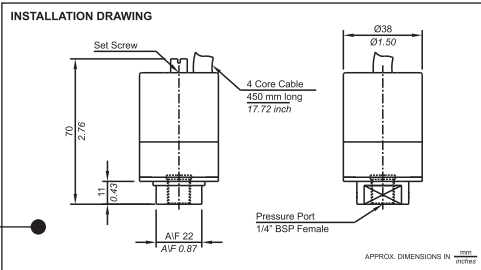

Set Screw

4 Core Cable
450 mm long
17.72 inch

Pressure Port
1/4" BSP Female

A/F 22
A/F 0.87

APPROX. DIMENSIONS IN mm/inches

Bulletin No. KA121024

OEM HIGH RANGE PRESSURE SWITCHES SM

3 ●

8 ●

9 ●

303

General information:
SM series pressure switches have a cast aluminium enclosure, intended for in-house use. These are generally used where size is a constraint. The repeat accuracy is better than ± 2% FSR. A core cable 450 mm long with CNCING contacts is provided for wiring. Pressure port is 1/4" BSPF standard.

Features:

- Compact
- Lightweight
- Electrical rating : 5A, 250VAC; 0.2A, 250 VDC(res.)
- Choice of wetted parts to suit working media
- Proof pressure available can be 4 times MWP (optional)
- Pressure port : 1/4" BSPF

Range Selection Table

Range Code	Range (rising pressure) bar (psi)	*Approximate Maximum Differential (fixed) bar (psi)	Maximum Working Pressure bar (psi)
H01	0.2 - 1.0 (2.90 - 14.50)	0.2 (2.90)	12 (174.05)
H03	0.2 - 2.4 (2.90 - 37.71)	0.3 (4.35)	12 (174.05)
H04	0.2 - 3.6 (2.90 - 52.52)	0.3 (4.35)	12 (174.05)
H07	0.5 - 7.0 (7.25 - 101.53)	0.5 (7.25)	12 (174.05)
H10	0.5 - 10.0 (7.25 - 145.04)	1.0 (14.50)	25 (362.6)
H15	1.0 - 15.0 (14.50 - 217.56)	1.5 (21.75)	25 (362.6)
H30	5.0 - 25.0 (72.52 - 362.6)	2.50 (36.26)	25 (362.6)

*Minimum differential increases with setpoint (Graphs available on request)

How to order SM Series High Range Pressure Switches

Group 1	Group 2	Group 3	Group 4	Group 5	Group 6
Model	Range Code	Range Scale	Pressure Housing	Diaphragm	Enclosure
SM - Fixed Differential Pressure switch	H - High range pressure switch	U - Uncalibrated	A - Aluminium B - Brass S - SS316	0 - Neoprene 1 - Teflon	0 - IP 54 as per IS 2147

eg. A single pressure switch, high pressure range from 0.1-1.0 bar in uncalibrated style with brass pressure housing & a teflon diaphragm in a standard enclosure shall be specified by

Group 1	Group 2	Group 3	Group 4	Group 5	Group 6
SM	H01	U	B	1	0

Please specify full model number to avoid ambiguity. If only the first two groups are specified while ordering, switches with standard wetted parts will be supplied.

Bulletin No. KA121024

HOW TO USE this section

6. Photos - will appear on the relevant top of the page for products. If there are mounting variations / styles, all the styles for standard products will appear for easy identification. Options, if included in the photograph, are for demonstration only, and are not a part of the standard equipment. For accessories, the photos are not given due to the sheer variety and range available.

7. Logo - will appear on right hand top of page to identify the manufacturer.

8. Characteristics - Range tables and their relevant data, e.g the range covered, the differentials and maximum working pressures will generally appear on the right hand page. Additional technical details will also be mentioned, wherever required, on the right hand side of the page.

9. Ordering guide - A guide as to how to order the particular series' variations will appear on right hand bottom of the page. Only the variations available within a particular product family / series will appear here. Any additional accessories or modifications required for the product need to be mentioned in text by the user.

10. Installation and Operating Instructions - will appear on the right hand page. This provides instructions for installation and operation of that switch.

11. Numerous combinations are possible when pressure switches are provided with accessories like chemical seals, snubbers, remote seals, pipe mounting brackets, combination of switches mounted in a panel etc. Users are requested to provide the details of accessories required in text / drawings, as separate identification codes are provided for pressure switches fitted and supplied with accessories.

1 ● **CF ULTRA LOW RANGE PRESSURE DIFFERENCE SWITCHES**

3 ● **Salient Features**

Easy to See, Easy to Use!
Set Point easily user adjustable with visible scale in Pascal. (no need of pressure gauge).

Differential easily adjustable with just a screwdriver

Light Weight!
150 gms

Flexible!
Direction of PG 11 cable entry can be rotated in steps of 120°

Long Lasting!
10⁷ switching operations

More Options!
Available in a wide range

Trusted all over!
Tested and proven

Technical Specifications

- Media - Air, non-flammable gases and non-aggressive gases.
- Housing Material - Body of PA 6.6 and Cover of PS
- Protection category - IP54 with cover.
- Maximum working pressure - 10 Kpa / 1019.74 mm wg.
- Electrical Rating - Maximum 1.0A (4 A) / 250 VAC.
- Electrical Connection - AMP flat plug 6.3 mm x 0.8 mm in accordance with DIN 46224.
- Cable Entry - PG11
- Mounting Lugs - integrated in bottom Housing.
- High Pressure and Low Pressure port of Outer Diameter 6 mm.

2 ● **Ultra Low Range Pressure Difference Switches with User Adjustable Knob**



6 ● **Range Selection Table**

Range Code (Orion)	Adjustment range for upper switching pressure Pa (mm wg)	Switching differential set to Pa (mm wg)
CF80	20 ~ 200 (2.039 ~ 20.395)	10 (1.020)
CF81	40 ~ 100 (4.079 ~ 10.197)	20 (2.039)
CF82	40 ~ 200 (4.079 ~ 20.395)	20 (2.039)
CF83	50 ~ 500 (5.099 ~ 50.987)	20 (2.039)
CF85	200 ~ 1000 (20.395 ~ 101.974)	100 (10.197)
CF86	500 ~ 2500 (50.987 ~ 254.935)	150 (15.296)
CF87	1000 ~ 4000 (101.974 ~ 407.896)	250 (25.494)

7 ● **Orion INSTRUMENTS**

9 ● **How to order CF series Low Range Pressure Difference Switches**
Please specify the Range Code eg. CF82 or CF85

Bulletin No. KA121024

318

ULTRA LOW RANGE PRESSURE DIFFERENCE SWITCHES ● **CF**

INSTALLATION AND OPERATING INSTRUCTIONS

Principle of Operation
When the effective force generated by the pressure difference in the lower and upper chamber of the pressure capsule exceeds/falls beyond the balancing spring forces, an electrical element is actuated.

Mounting
The detail mounting dimensions are shown in Fig. 1

Fig. 1

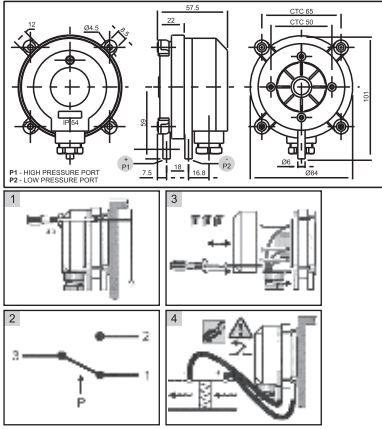

5 ●

10 ●

P1 = higher pressure
P2 = lower pressure
*Use two screws only, for mounting
**Remove transport protection from P2
Note : Do not install upside down with trip pressure of less than 50 Pa.

Bulletin No. KA121024

319

8

Product Selection Guide



Page No. 300



Page No. 302



Page No. 304

Model	SC	SM	SA
Switch type	Subminiature	OEM (High Pr.)	OEM (High Pr.)
Differential type	Fixed	Fixed	Fixed
Repeatability (% FSR)	± 2	± 2	± 2
Range covered	0.1 bar to 25 bar	0.2 bar to 25 bar	0.2 bar to 25 bar
Enclosure Protection			
Enclosure Standard	Cast aluminium	Cast aluminium to IP 54 as per IS 2147	
Enclosure Optional			
sensing element Standard	Diaphragm		
sensing element Optional	teflon, SS316L	nylon reinforced	neoprene diaphragm teflon
Pressure housing Standard	SS 316 mild steel	Aluminium	
Pressure housing Optional		Brass/SS316	
Other Wetted Parts			
Optional wetted parts through chem. seal			
Temp. of working medium	80°C maximum. For higher temperature, please use impulse tubing/chemical seals.		
Switching element	SPDT Snap action switch A8 : General purpose rated at 5A, 250 VAC, 0.2 A, 250 VDC resistive. For other switching elements please contact sales office		

WETTED PARTS

Accessories can be supplied with most of the switches. Please consult sales office.

Product Selection Guide



Page No. 306



Page No. 306

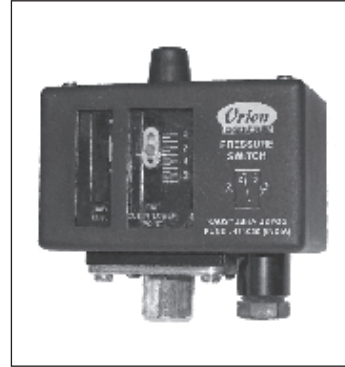

Page No. 308

EZ	EX	EZ_A	Model
OEM (High Pr.)	OEM (High Pr.)	OEM (High Pr.)	Switch type
Fixed	Adjustable	Fixed	Differential type
± 1.5	± 1.5	± 1.5	Repeatability (% FSR)
0.2 bar to 25 bar	0.5 bar to 25 bar	3 psi to 350 psi	Range covered
			Enclosure Protection
Pressed steel enclosures IP 40 as per IS 2147			Enclosure Standard Optional
Diaphragm Teflon			sensing element Standard Optional
SS316			Pressure housing Standard Optional
			Other Wetted Parts
			Optional wetted parts through chem. seal
80°C maximum. For higher temperature, please use impulse tubing/chemical seals.			Temp. of working medium
SPDT Snap action switch A8 : General purpose rated at 5A, 250 VAC, 0.2 A, 250 VDC resistive. For other switching elements please contact sales office			Switching element

WETTED PARTS

Accessories can be supplied with most of the switches. Please consult sales office.

Product Selection Guide



Page No. 308



Page No. 310



Page No. 310

Model	EX_A	MZ	MX
Switch type	OEM (High Pr.)	OEM (High Pr.)	OEM (High Pr.)
Differential type	Adjustable	Fixed	Adjustable
Repeatability (% FSR)	± 1.5	Various	
Range covered	7 psi to 350 psi	0.1 bar to 25 bar	0.5 bar to 25 bar
Enclosure Protection		IP 66	
Enclosure Standard Optional	Pressed steel enclosures IP 40 as per IS 2147	Tough transparent polycarbonate	
sensing element Standard Optional	Teflon	Various	
Pressure housing Standard Optional	SS 316		
Other Wetted Parts		Teflon, SS 316	
Optional wetted parts through chem. seal			
Temp. of working medium	80°C maximum. For higher temperature, please use impulse tubing/chemical seals.		
Switching element	SPDT Snap action switch A8 : General purpose rated at 5A, 250 VAC, 0.2 A, 250 VDC resistive. For other switching elements please contact sales office		

Accessories can be supplied with most of the switches. Please consult sales office.

Product Selection Guide



Page No. 312

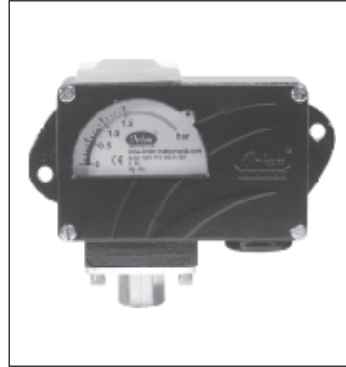

Page No. 314

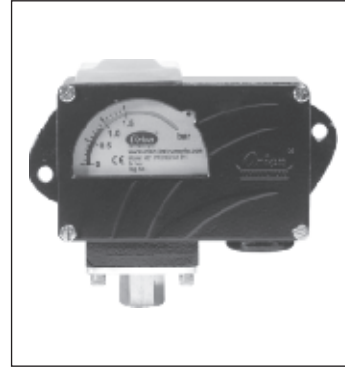

Page No. 316

MZ__A	MD	MD__A	Model
OEM (High Pr.)	OEM (High Pr.)	OEM (High Pr.)	Switch type
Fixed	Fixed		Differential type
Various	± 2		Repeatability (% FSR)
1.5 psi to 350 psi	0.1 bar to 25.0 bar	1.5 psi to 350 psi	Range covered
IP 66			Enclosure Protection
Tough transparent polycarbonate	Die-cast aluminium		Enclosure Standard Optional
Diaphragm nylon reinforced neoprene diaphragm teflon			sensing element Standard Optional
SS 316			Pressure housing Standard Optional
Teflon, SS316			Other Wetted Parts
			Optional wetted parts through chem. seal
80°C maximum. For higher temperature, please use impulse tubing/chemical seals.			Temp. of working medium
SPDT Snap action switch A8 : General purpose rated at 5A, 250 VAC, 0.2 A, 250 VDC resistive. For other switching elements please contact sales office		Maximum 1.0 A (.4A) / 250 VAC	Switching element

WETTED PARTS

Accessories can be supplied with most of the switches. Please consult sales office.

Product Selection Guide

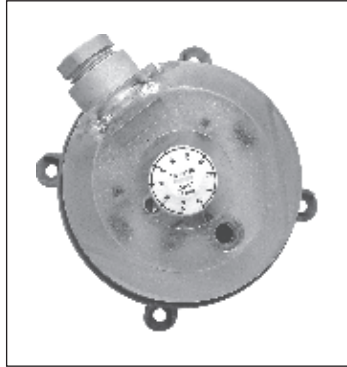

Page No. 318



Page No. 320

Model	CF	CS12
Switch type	OEM (Ultra-low Range)	OEM
Differential type	Adjustable	Adjustable
Repeatability (% FSR)		
Range covered	20 Pa to 4000 Pa	2 bar to 12 bar
Enclosure Protection	IP 54	IP44
Enclosure Standard Optional	Body of PA 6.6 and Cover of PS	Non-metallic cover
sensing element Standard Optional		Nitrile rubber
Pressure housing Standard Optional	Industrial Plastic	Mild Steel
Other Wetted Parts		
Optional wetted parts through chem. seal		
Temp. of working medium	80°C maximum	
Switching element	Maximum 1.0 A (.4A) / 250 VAC	16 Amp, 500 VAC

WETTED PARTS

Accessories can be supplied with most of the switches. Please consult sales office.

EZ / EX OEM HIGH RANGE PRESSURE SWITCHES



PRESSURE CAPSULE DETAILS

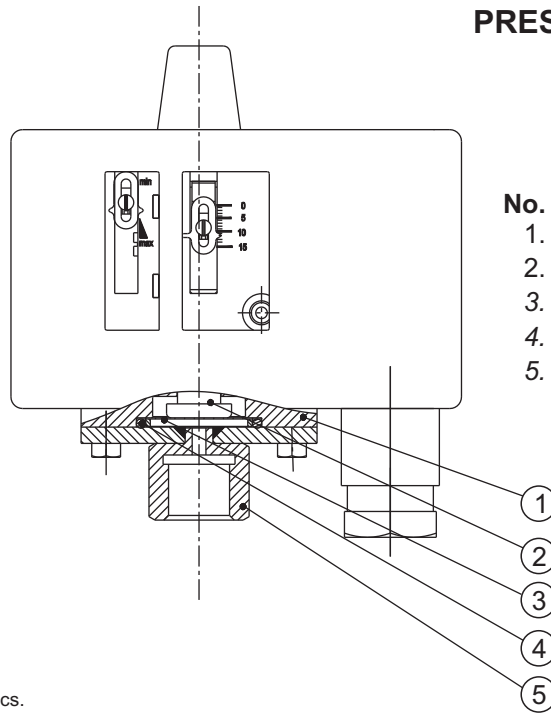

- | No. | Description |
|-----|---------------------------|
| 1. | Disc |
| 2. | Plunger |
| 3. | Diaphragm (Teflon) |
| 4. | O ring (Teflon) |
| 5. | Pressure Housing (SS 316) |

Note : *wetted parts* are mentioned in italics.

INSTALLATION DRAWING

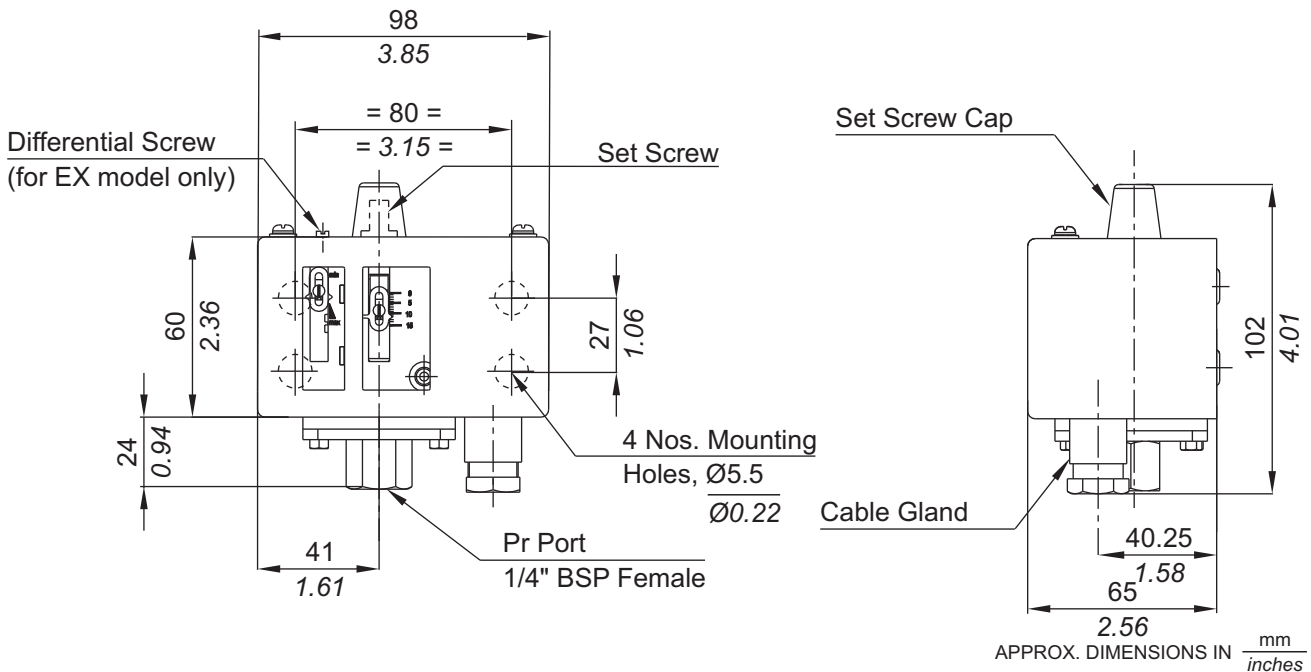

OEM HIGH RANGE PRESSURE SWITCHES **EZ / EX**

General information:

EZ /EX series pressure switches are housed in pressed steel powder coated enclosure and are recommended for panel mounting or indoor service. The repeat accuracy is better than $\pm 1.5\%$ FSR. A 3/8" cable entry is provided for cables and a terminal strip suitable for wired ends is provided inside the enclosure. Pressure port is 1/4" BSPF standard.

Features:

- Compact
- SS316 & Teflon as standard wetted parts
- Electrical rating : 5A, 250 VAC; 0.2A, 250VDC (res.)
- Pressure port: 1/4" BSPF

Range Selection Table

Model Code	† Range bar (psi)	*Approximate Maximum Differential bar (psi)	* Adjustable Differential bar (psi)	Maximum Working Pressure bar (psi)
EZ4	0.2 - 3.6 (2.90 - 52.21)	0.20 (2.90)	-	12 (174.05)
EZ7	0.5 - 7.0 (7.25 - 101.52)	0.40 (5.80)	-	12 (174.05)
EZ15	1.0 - 15.0 (14.50 - 217.71)	0.60 (8.70)	-	25 (362.6)
EZ30	5.0 - 25.0 (72.52 - 362.6)	1.00 (14.50)	-	35 (507.63)
EX7	0.5 - 7.0 (7.25 - 101.52)	-	0.8 - 6.0 (11.60 - 87.02)	12 (174.05)
EX15	1.0 - 15.0 (14.50 - 217.71)	-	1.5 - 10.0 (21.76 - 145.04)	25 (362.6)
EX30	5.0 - 25.0 (72.52 - 362.6)	-	2.5 - 10.0 (36.26 - 145.04)	35 (507.63)

*Minimum differential increases with setpoint (Graphs available on request)

† rising pressure for EZ series; falling pressure for EX series

HOW TO ORDER EZ/EX OEM HIGH RANGE PRESSURE SWITCHES

Please specify model code as per range selection table above.

EZ__A / EX__A

OEM HIGH RANGE PRESSURE SWITCHES



PRESSURE CAPSULE DETAILS

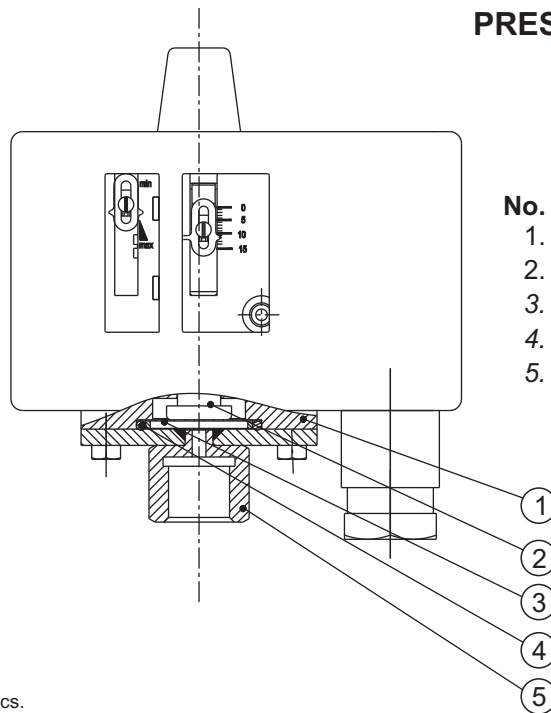

No. Description

1. Disc
2. Plunger
3. Diaphragm (Teflon)
4. O ring (Teflon)
5. Pressure Housing (SS 316)

Note : *wetted parts* are mentioned in italics.

INSTALLATION DRAWING

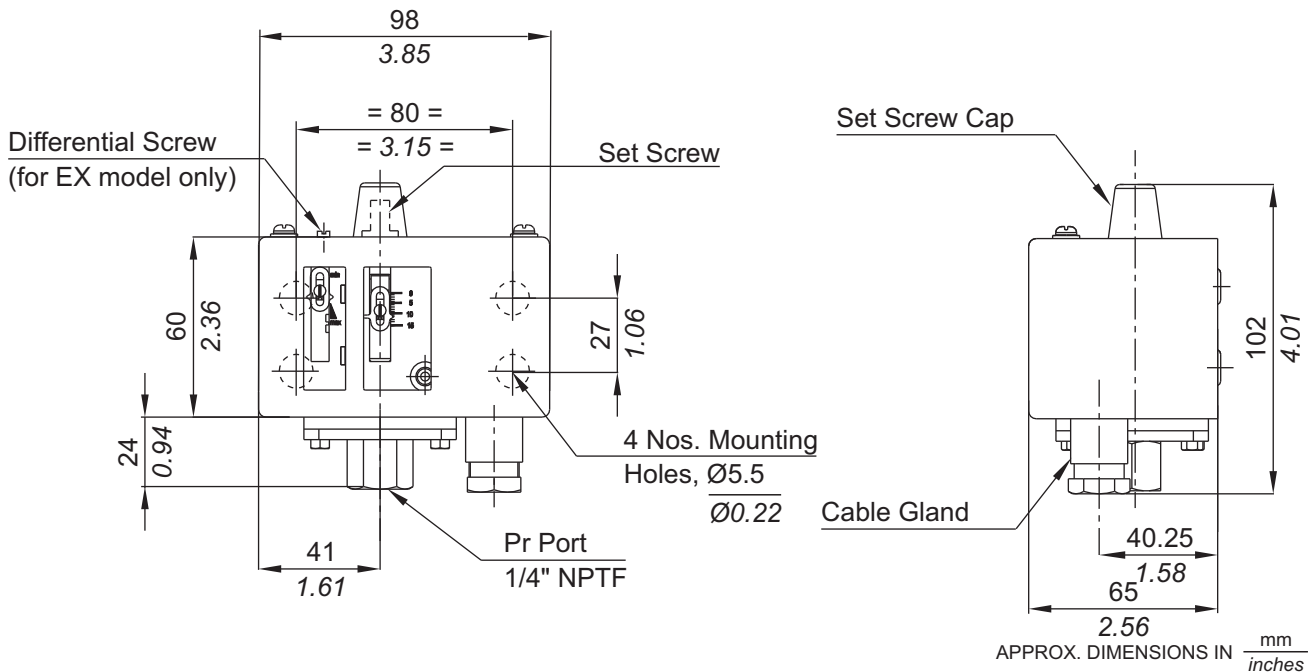

OEM HIGH RANGE PRESSURE SWITCHES

EZ__A / EX__A

General information:

EZ /EX series pressure switches are housed in pressed steel powder coated enclosure and are recommended for panel mounting or indoor service. The repeat accuracy is better than $\pm 1.5\%$ FSR. A 3/8" BSP cable entry is provided for cables and a terminal strip suitable for wired ends is provided inside the enclosure. Pressure port is 1/4" NPTF standard.

Features:

- Compact
- SS316 & Teflon as standard wetted parts
- Electrical rating : 5A, 250 VAC; 0.2A, 250VDC (res.)
- Pressure port: 1/4" NPTF

Range Selection Table

Model Code	† Range psi	*Approximate Maximum Differential psi	* Adjustable Differential psi	Maximum Working Pressure psi
EZ4A	3.0 - 50.0	3.0	-	200.0
EZ7A	7.0 - 100.0	6.0	-	200.0
EZ15A	15.0 - 200.0	6.0	-	350.0
EZ30A	70.0 - 350.0	6.0	-	500.0
EX7A	7.0 - 100.0	-	10.0 - 90.0	200.0
EX15A	15.0 - 200.0	-	20.0 - 150.0	350.0
EX30A	70.0 - 350.0	-	40.0 - 150.0	500.0

*Minimum differential increases with setpoint (Graphs available on request)

† rising pressure for EZ series; falling pressure for EX series

HOW TO ORDER EZ__A/EX__A OEM HIGH RANGE PRESSURE SWITCHES

Please specify model code as per range selection table above.

ACCESSORIES

Following accessories can be provided with pressure switches to make it suitable for any particular application.

- | | |
|--|---|
| Flameproof enclosures | syphons |
| Chemical seals (or diaphragm seals) | manifolds |
| adaptors to suit customer's process connection | pipe mounting brackets |
| switch savers | mounting plates to suit other makes on the market |
| impulse tubes | snubbers |
| | tag plates (to display tag no. and identify the instrument) |

Installation drawings of most common and fast moving accessories are given. The wetted parts, wherever applicable, are not specified due to the extreme variety available.

MOUNTING PLATE

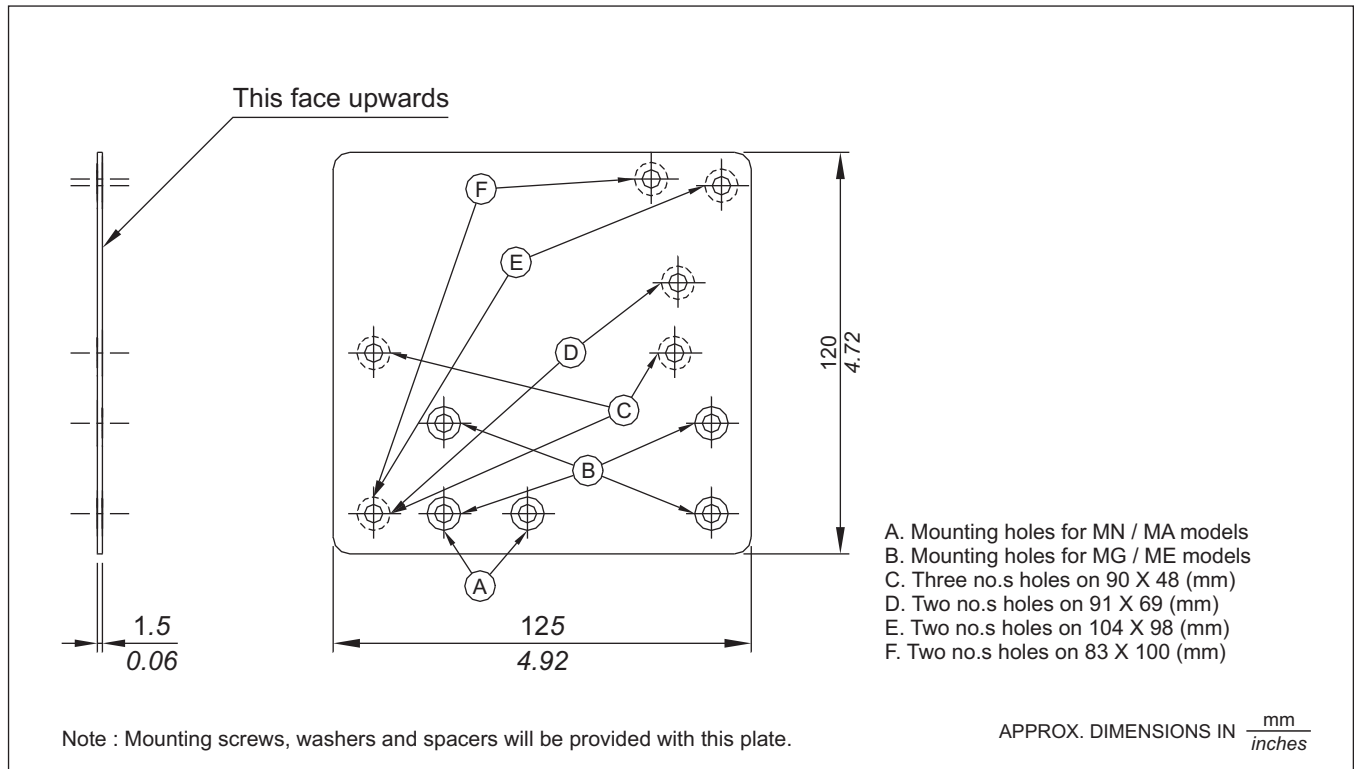

ACCESSORIES

Gauge Saver



A OPP 1 = Set Pressure: 0.6 to 2.0 bar
 A OPP 2 = Set Pressure: 2.5 to 200 bar

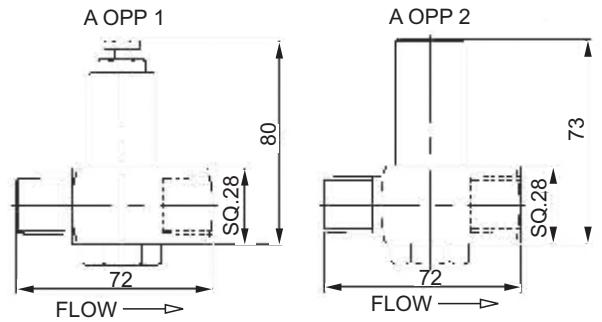

2 Valve Manifold

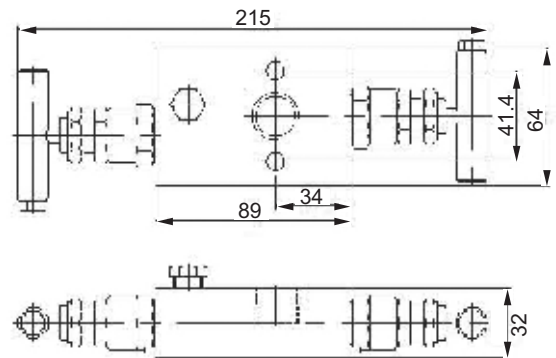

3 Valve Manifold

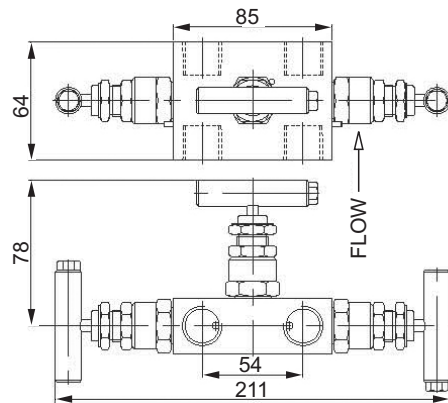

Snubber



SIZE	A	B
1/4"NPT	55	25
3/8"NPT	55	25
1/2"NPT	63	28
G1/2"	63	28

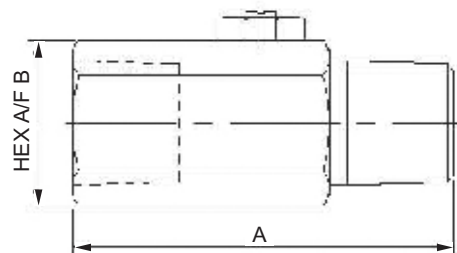

ACCESSORIES

CHEMICAL SEALS (DIAPHRAGM SEALS):

General description:

Diaphragm seals are partitions used with pressure switches which prevent the measured medium from entering the pressure capsule of the pressure switch. Diaphragm seals solve many problems encountered in sensing, which are otherwise impossible to solve with only pressure switches. Some of the examples are:

- protection of pressure switch from aggressive, highly viscous solidifying or crystallizing measured media
- protection from high measured medium temperatures or fluctuations in temperature
- protection from vibrations by coupling via capillaries
- dead zone free sensing arrangements for particular hygienic applications
- use of special materials or surface coatings of the wetted parts for special applications.

CAUTION: Pressure switch and diaphragm seal are always a closed system and should not be separated by unauthorised persons.

When the pressure switch is to be kept away from undesirable temperatures or vibrations, a capillary can be used to connect the pressure switch and the diaphragm seal. Capillaries also have a throttling effect which is often desirable in pulsating process pressures. During setpoint adjustment, the weight of the liquid column between the diaphragm seal and the pressure switch needs to be taken into consideration, if they are mounted at different elevations.

Depending on the application, a variety of media with different properties are used as transmission liquids. For most of the general applications, silicon oil can be used. For food industries, a transmission liquid compatible with the process needs to be used.

A variety of chemical seals can be supplied with pressure switches and only the most commonly used arrangements / assemblies are shown here.

In most of the cases, the common wetted parts and diaphragms are of SS316. Alternate wetted materials that can be provided are:

- HASTELLOY B2
- HASTELLOY C4
- HASTELLOY C22
- HASTELLOY C276
- INCONEL ALLOY 600
- MONELALLOY 400
- MONELALLOY K500
- NICKEL
- PLATINUM
- TANTALUM
- TITANIUM
- ZIRCONIUM
- SILVER
- PTFE

The on - off differentials of pressure switches fitted with chemical seals are likely to be higher than those mentioned in the catalogue. There is also a possibility of time lag (for sensing) being introduced, depending on the length of the tubing between the pressure switch and the seal.

While ordering, customer's are requested to specify all the process parameters including ambient conditions, operating conditions, the process to be sensed and response times allowable, temperature of the seal under sensing conditions and temperature outside the measuring / sensing sequences (e.g as in rinsing sequences) so that a proper sealing system can be suggested.

ACCESSORIES

STANDARD CHEMICAL SEAL SUITABLE FOR THREADED CONNECTION : (Type A)

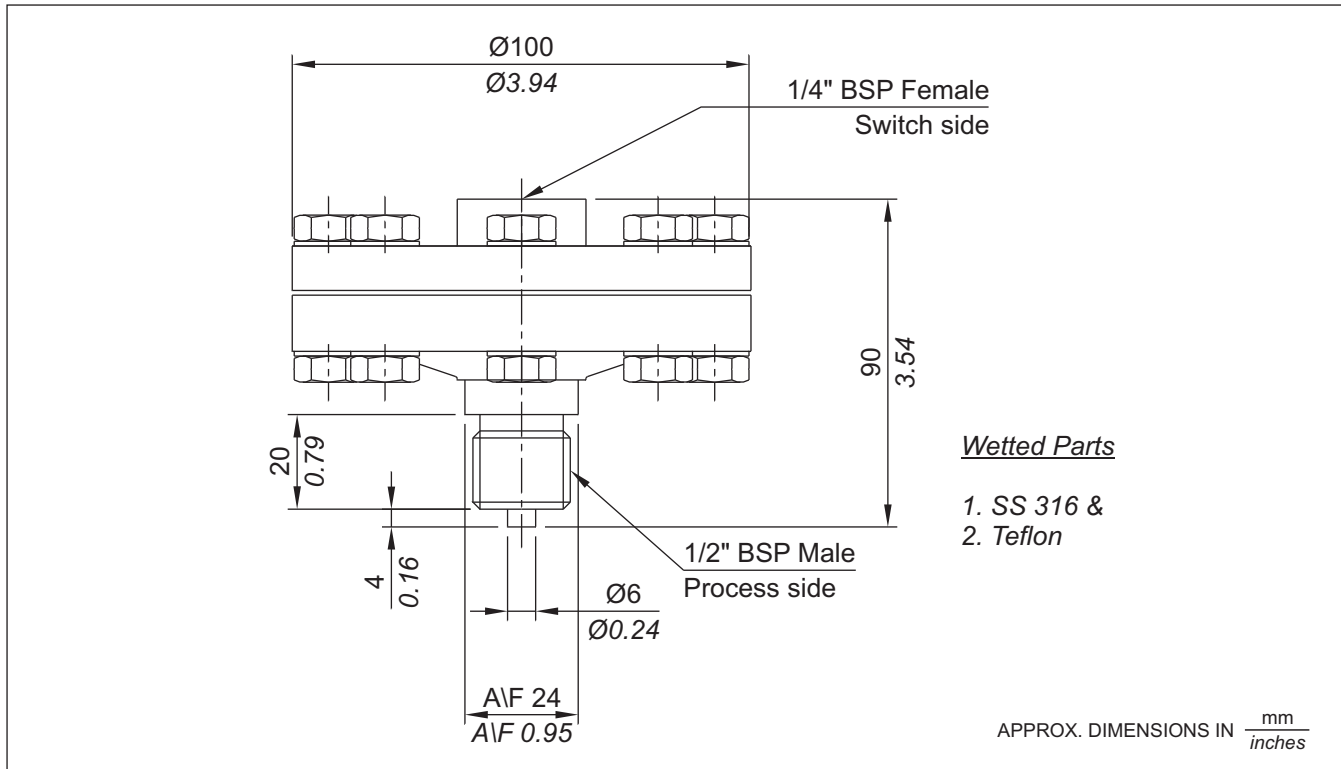

CHEMICAL SEAL SUITABLE FOR VARIABLE FLANGED CONNECTION : (Type B)

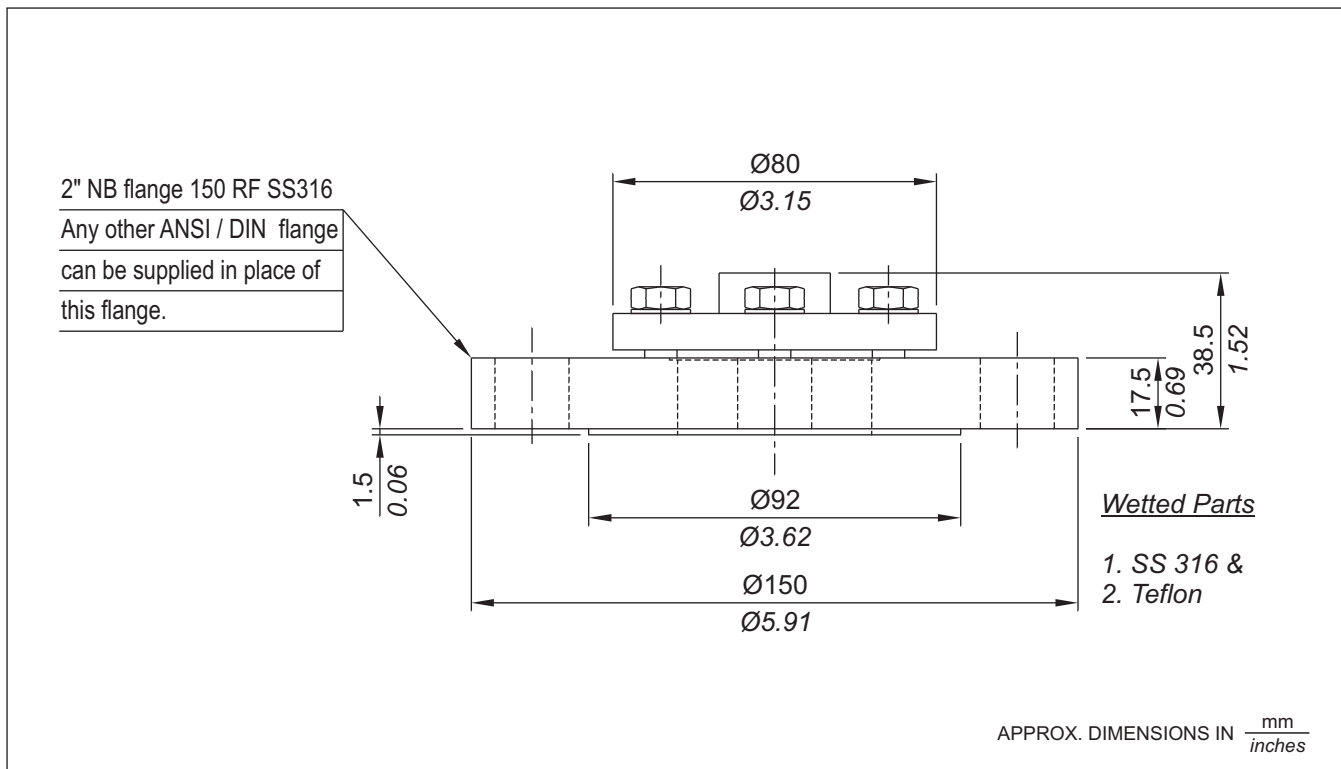

ACCESSORIES

FLUSH TYPE CHEMICAL SEAL (Type C)

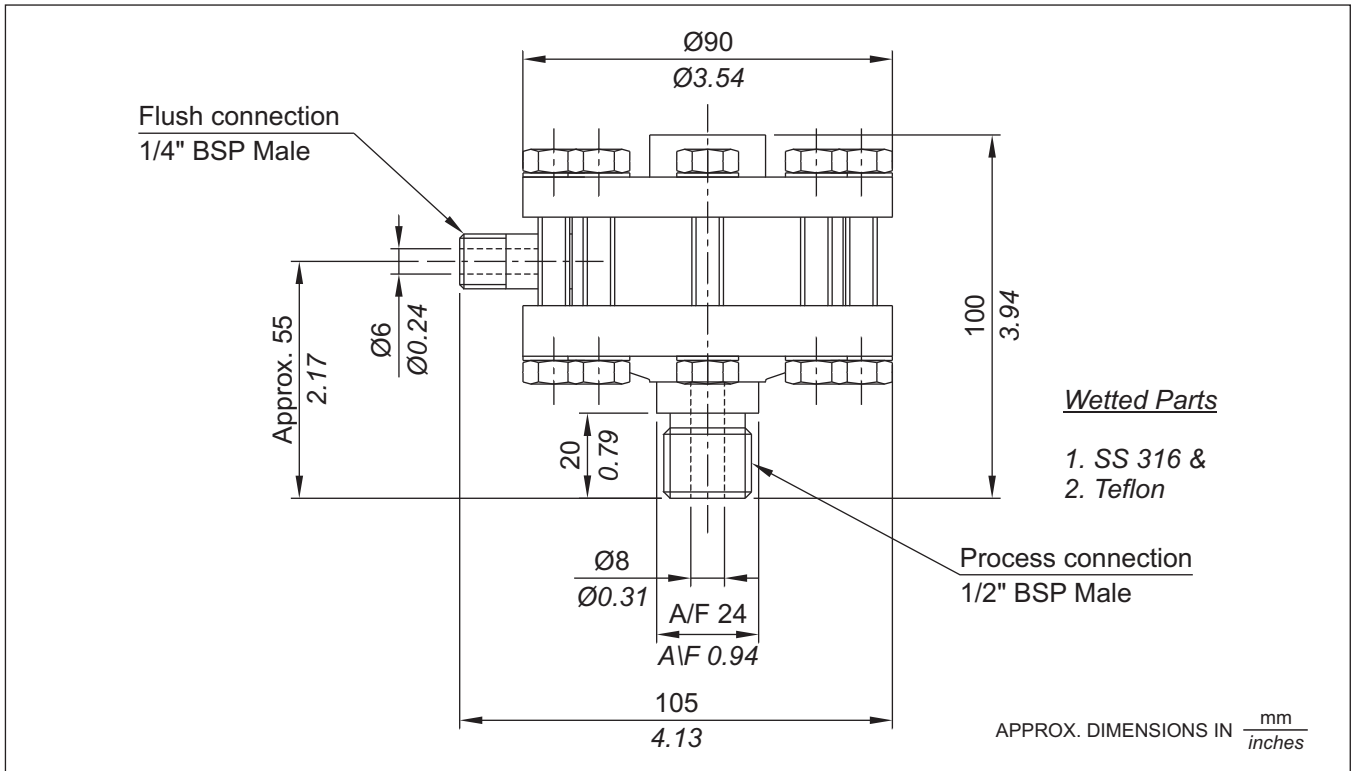

FULL WELDED CHEMICAL SEAL (Type D)

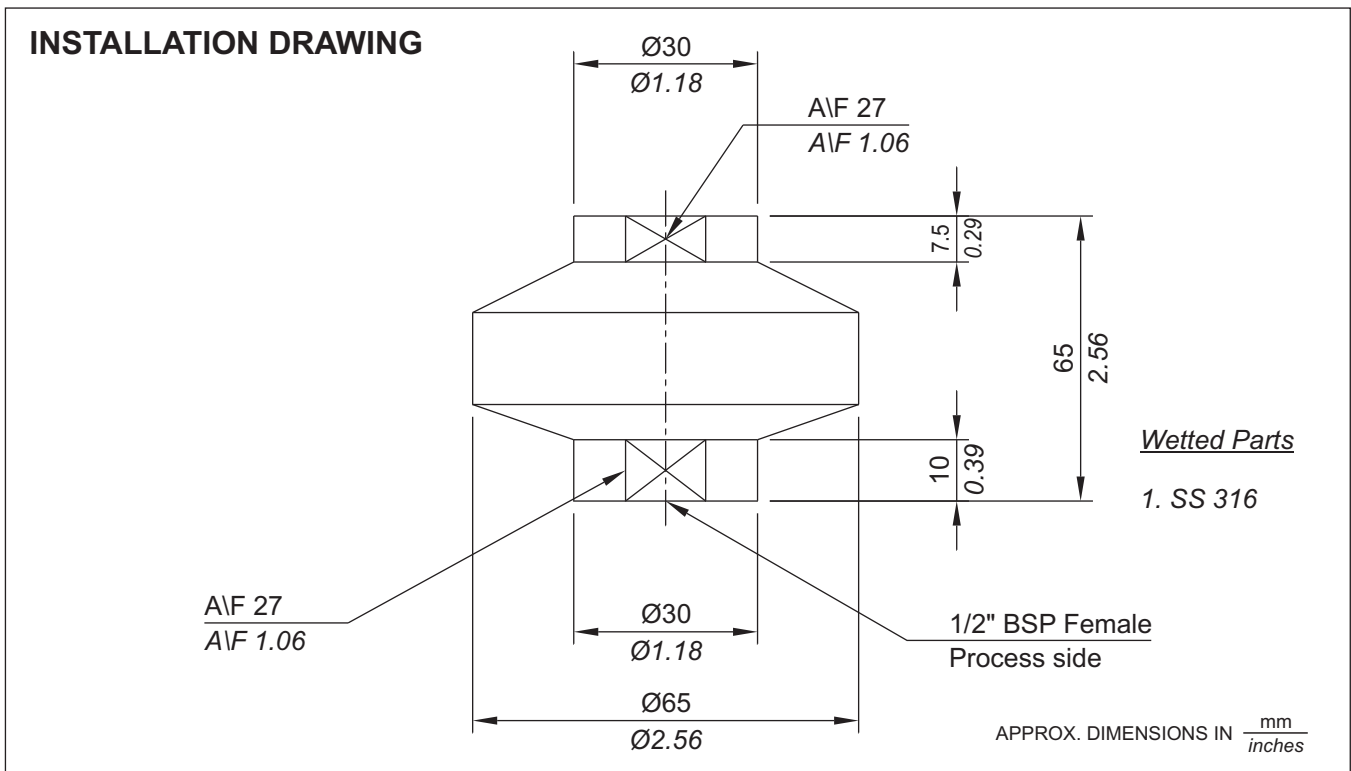

GENERAL SPECIFICATIONS AND APPLICATION NOTES

1. All the pressure switches contained in this catalogue are gauge pressure switches.
2. Pressure switches are switching instruments and not measuring ones. As such, the word "calibration" is used for the markings made on the scale to indicate the approximate setpoint of the pressure switch. No "calibration certificate" for this indication can be given in the proper sense of the word. However, the pressure switches can be supplied preset at user specified setpoints, provided the setpoints are indicated during the ordering stage itself.
3. Process temperature : can be 80 deg. C maximum. A pressure switch being a dead end, is not subjected to continuous process temperature(as in case of flow). As such, a proper length of impulse tubing of proper material (or chemical seals with adequate tubing) will substantially bring down the temperature, well within the specified limits. Normal pressure switches (without any modifications) have been used with working media having a temperature of upto 350 deg. C, only by employing an additional impulse tube.
4. Ambient temperature: can be from -10 deg. C to 60 deg. C for most of the standard pressure switches. Care should be taken that no icing occurs inside the enclosure where the atmospheres are humid, when pressure switches are used in subzero ambient temperature areas. Pressure switches for use in wider ambient temperatures can be developed should your application fall in such areas. If the process is likely to freeze / crystallize / solidify within this ambient range, chemical seals should be used alongwith the pressure switches.
5. All the pressure switches are tested on kerosene / air prior to despatch. For applications involving food grade material / oxygen service or processes not compatible with kerosene, such a note should be specifically made while ordering, so that pressure switches are tested accordingly.
6. All data published is under standard test conditions. Following conditions generally apply for Laboratory Evaluation tests:

Temperature	: Ambient room temperature (21 °C)
Humidity	: Ambient (50%)
Proof pressure	: 1.5 times maximum working pressure
Cycling rate	: 30 cycles/minute
Pressure rise	: compatible with above cycling rate (maximum)
Life in no. of cycles	: 100,000 minimum

The life and characteristics of pressure switches can be affected by temperature, humidity, airborne contamination, vibration and frequency of operation of the pressure switches. For specific switch selection, customers are requested to evaluate switch performance under actual application conditions or by simulating all the extreme application conditions and requirements. Laboratory Evaluation test data can never substitute customer's own product evaluation.

The life of the pressure switches can be increased by incorporating changes in design or by substituting certain components. Customers are requested to contact our sales office for any such specific requirements.

DEFINITIONS & TERMINOLOGY FOR PRESSURE ACTUATED SWITCHES

Pressure Switch:- A pressure switch is an instrument that automatically senses a change in pressure and opens or closes an electrical switching element when a pre-determined pressure point is reached.

Pressure sensing element:- A pressure sensing element is the portion of the pressure switch that transmits motion due to change in pressure.

Electrical switching element:- The electrical switching element in a pressure switch opens or closes an electrical circuit in response to the actuating force it receives from the pressure sensing element. Orion pressure switches are fitted with single pole double throw (SPDT) snap action switch(es) as electrical switching element (s) for maximum reliability.

Normally open switching element:- No current can flow through the switching element until the switch is actuated.

Normally closed switching element:- Current flows through the switching element until the switch is actuated.

Set Point:- The set point is expressed in terms of exact pressure at which the snap-action switch is actuated to either open or close the electrical circuit (depending on how the switch is wired).

Differential (Dead band, Hysteresis):- Differential is the difference between the actuation point and the deactuation point, e.g. if a pressure switch is set to operate at 5 bar on increasing pressure, the switch will close when the pressure rises to that point. As the pressure drops to, say, 4.8 bar the switch may open (this is the deactuation point). The differential of this switch is then 0.2 bar, the difference between the set point of 5 bar and deactuation point of 4.8 bar. Differential is sometimes referred to as "deadband" or "hysteresis".

Set Point in relation to increasing pressure & decreasing pressure:- A pressure switch may be set to actuate at any desired point on rising pressure or falling pressure. The former is described as "set to actuate on increasing (or rising) pressure" & the latter as "set to actuate on decreasing (or falling) pressure". The preferred actuation must be specified clearly on orders for pressure switches that are to be factory set.

Range :- The span within which the set point of a pressure-actuated switch may be adjusted.

Proof Pressure :- Proof pressure is the highest pressure to which a switch may be subjected without permanent damage.

Maximum working pressure (MWP) :- The nominal pressure level that a system will operate at, including workload.

Differential pressure :- The difference between a reference pressure and a variable pressure.

Wetted parts :- The parts which come in contact with the working medium.

HOW TO SELECT A PRESSURE SWITCH FOR YOUR APPLICATION

Following are the general guidelines which should help you arrive at a proper selection of a pressure switch for your application.

Step 1.

Service life of the switch. Expected service life is the first consideration to be made in selecting a pressure switch, regardless of sensitivity or pressure desired. A second consideration in choosing a pressure switch is the speed of cycling, regardless of the service life. A sensing element made of metal sheets is likely to fatigue at cycling speeds above 20 cycles per minute and is not recommended for service life of more than 1 million cycles. Orion and Parus pressure switches use nylon reinforced rubber or piston as a sensing element and have been tested at a cycling frequency of 30 cycles / minute for more than a million cycles. The working medium to be controlled must be considered and to simplify selection, wetted parts are indicated on the catalogue pages.

Step 2.

Proof pressure - Choice of type of pressure switch must also be governed by the highest pressure to which it will ever be subjected. The highest pressure in the system including surges, should not be more than the proof pressure of the switch. It must be remembered that, though there are surges in the system, a pressure gauge may register a constant reading, the surges being dampened out by the orifice in the gauge.

Step 3.

Function of the switch. Three types of Orion pressure switches, based on function, are described below, a) Single setting pressure switches : They sense a single pressure source and open or close a single electrical circuit by means of a snap action electrical switch. b) Pressure difference switches : They sense a change in relationship between two pressures and open or close a single electrical circuit by means of a snap action electrical switch. c) Adjustable differential pressure switches: They sense two pressure limits, within a desired adjustable range, from a single pressure source and open or close a single electrical circuit by means of a snap action electrical switch.

Step 4.

Selection of adjustable range. The range should be selected such that the setpoint lies as close as possible to the middle of the total adjustable range. This will ensure the most favourable combination of accuracy and life.

Step 5.

Working medium. The working medium should be compatible with the wetted parts. For easier selection, the wetted parts are given in the catalogue pages. The maximum temperature of the working medium is also important. A pressure switch, being a dead end, is not subjected to continuous temperature. If the temperature of the working medium exceeds 80 deg. C, an impulse tubing of appropriate length should be used between the process connection and pressure port of the switch. Where the working medium is likely to freeze at the sensing element, a diaphragm seal (chemical seal) with appropriate wetted parts should be used. In case of excessive temperature or mounting the pressure switch remotely, pressure switches can also be supplied with remote seals. The filling medium has to be compatible with the working medium, and needs to be specified while ordering. (Specially in case of food related industries / processes)

Step 6.

Environment. The environment in which the pressure switch will operate is very important. Orion pressure switches can be supplied in weatherproof enclosures for outdoor service. For use of pressure switches in hazardous areas Orion pressure switches can be supplied in flameproof enclosures.