

COMPACT SWITCHES

SPECIFIER'S GUIDE FOR

PRESSURE SWITCHES

PRESSURE DIFFERENCE SWITCHES

VACUUM SWITCHES

VS1 *Serisi*

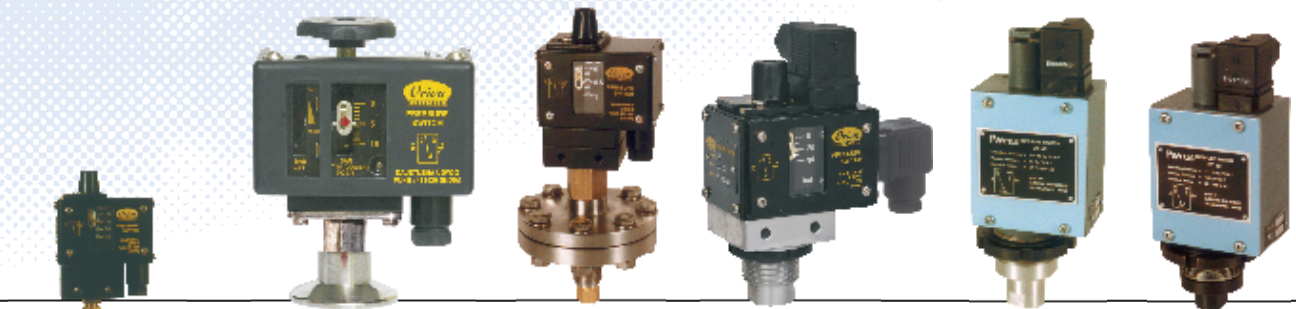

Using the section

This section on helps you make a logical choice in selecting the best product for a particular application. It allows a user familiar with our product line to locate the exact page the product is listed on. For those not familiar with our products, a logical sequence is given to help the user pick the best product for their need.

By taking a few minutes to familiarise yourself with the catalogue organization, you will find it very easy to locate the product / information you need.

1. The contents page lists the broad outline in which the catalogue is organized, and will help the user familiar with products to select the page on which the product or other useful information is listed.

2. Need Product Selection help ?

Product selection help will start with the “Pictorial Index” on Page 235, where the products are broadly classified. A brief description of each product group , a typical photo of the product within the group and the page number on which it is listed are given.

If the user is not familiar with the products, a product selection guide is provided on pages 238 through 244, where photos for each product and important specifications are given to help determine and select the best product for the application.

By evaluating and comparing these parameters, a logical selection can be made. Turn to the page on which the product information for the selected product is listed, for :

Capsule Construction details

Physical sizes

Special features

Ranges, hysteresis, electrical ratings etc.

Ordering information

Some applications

The organisation of each of these pages is demonstrated on pages 236 and 237, of this section “How to use this catalogue”.

In many cases, more than one product may work. For the most cost effective solution, compare prices and consider alternatives. Remember, the end cost includes initial product price, plus the installation, plus the service.

3. Need the terminology explained? (see page 330)

Turn to page 330 for the definitions and terminology. This will help you familiarize with the terms used throughout the catalogue.

4. Need information on Accessories? (see page 322)

Turn to page 322 for information on important accessories. These will give information on only important accessories, and information needed, when these are to be supplied with our products.

5. Need selection guidance? (see page 331)

A logical procedure on page 331 will help you to consider most of the important factors when selecting a pressure switch.

6. Need other products ? (see page 332)

Products other than those listed in this catalogue are referenced on these pages. Separate catalogues for these products are available.

PRESSURE SWITCHES

HIGH RANGE

MG/ME



P. No. 246

MN/MA



P. No. 248

HM



P. No. 258

DT



P. No. 264

MJ



P. No. 274

MK



P. No. 276

LOW RANGE

MN/MA



P. No. 272

HYGEINE RANGE

MG/ME TRICLOVER



P. No. 256

HYDRAULIC RANGE*

DN/DA



P. No. 250

HM



P. No. 260

DT



P. No. 266

DJ



P. No. 252

DK



P. No. 254

HM350



P. No. 262

PRESSURE DIFFERENCE SWITCHES

HIGH RANGE

PD

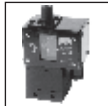

P. No. 280

DP



P. No. 278

PJ



P. No. 282

LOW RANGE

PD



P. No. 284

PA



P. No. 286

VACUUM SWITCHES

HIGH RANGE

VS1



P. No. 270

MN/MA



P. No. 268

LOW RANGE

Low range pressure difference switches can be used as vacuum switches when high pressure port is vented to atmosphere

*Hydraulic ranges are ranges typically from 2 bar to 600 bar, used in oil applications. However, these switches can be used for other media depending on wetted parts compatibility.

HOW TO USE this catalogue

Due to the variety in product types and their salient features, catalogue page formats may vary. But generally the following format is adhered to.

Elements appearing on each page will be:

1. Product family / series - A product family / series will appear on the outside page corner, depending on the left / right hand page, and will be in large bold type.
2. Product description - will appear immediately following the product family / series at top of the page and will be in bold type.
3. Features - will appear next to product description & will enlist only the major attributes.
4. Pressure capsule details - will show the construction of the pressure capsule and all its internal parts. If the process / working medium is variable, the wetted parts will be mentioned in italics. If the wetted parts are unique, the material of construction (MOC) will be mentioned

alongside in brackets. Where the material of construction is not specified, it will vary and the options are to be selected by the user considering the compatibility of the process / working medium. Modifications can be made to suit any particular medium, if the answer for your needs is not in the standard MOC listed. Products for which process / working medium is predefined, pressure capsule details are not provided (e.g as in case of comparison test pump). Pressure capsule details of accessories are not given.

5. Installation drawing - will show the typical installation dimensions of products as they exist in their standard forms. The dimensions are mentioned in millimetres and also in inches to facilitate the user. The dimensions of accessories will have to be added to these to arrive at any particular general arrangement (GA) drawings. The dimensions are approximate and for precise dimensions, where mounting space is restricted, the user may contact the nearest sales office. Installation drawings of only fast moving accessories are given.

DP HIGH RANGE PRESSURE DIFFERENCE SWITCHES





PRESSURE CAPSULE DETAILS

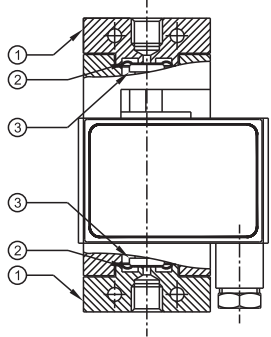

No. Description
1. Pressure housing
2. Diaphragm
3. Plunger

Note : wetted parts are mentioned in italics.

INSTALLATION DRAWING

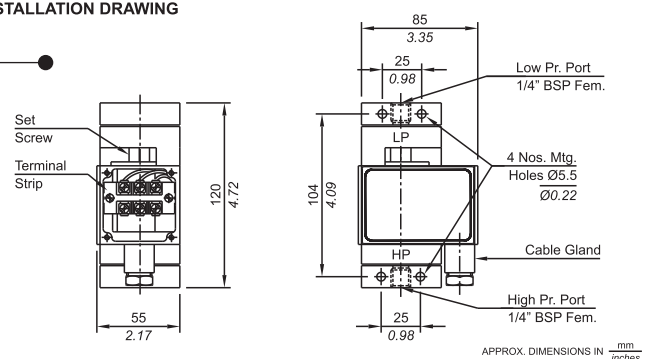

APPROX. DIMENSIONS IN $\frac{mm}{inches}$

Bulletin No. KA121024

278

HOW TO USE this catalogue

6. Photos - will appear on the relevant top of the page for products. If there are mounting variations / styles, all the styles for standard products will appear for easy identification. Options, if included in the photograph, are for demonstration only, and are not a part of the standard equipment. For accessories, the photos are not given due to the sheer variety and range available.

7. Logo - will appear on left hand top of page to identify the manufacturer.

8. Characteristics - Range tables and their relevant data, e.g the range covered, the differentials and maximum working pressures will generally appear on the right hand page. Additional technical details will also be mentioned, wherever required, on the right hand side of the page.

9. Ordering guide - A guide as to how to order the particular series' variations will appear on right hand bottom of the page. Only the variations available within a particular product family / series will appear here. Any additional accessories or modifications required for the product need to be mentioned in text by the user.

10. Some applications - will appear under features. This is for easy understanding of the specific use of the product.

11. Numerous combinations are possible when pressure switches are provided with accessories like chemical seals, snubbers, remote seals, pipe mounting brackets, combination of switches mounted in a panel etc. Users are requested to provide the details of accessories required in text / drawings, as separate identification codes are provided for pressure switches fitted and supplied with accessories.

HIGH RANGE PRESSURE DIFFERENCE SWITCHES DP

General information:
DP series pressure difference switches are housed in pressure die cast aluminium powder coated enclosure and are recommended for panel mounting or indoor service based on the type of enclosure opted for. The repeat accuracy is better than $\pm 1\%$ FSR. A 3/8" cable entry is provided for cables and a terminal strip suitable for wired ends is provided inside the enclosure. Pressure ports are 1/4" BSPF standard.

Features:

- Compact
- Separate chamber for working parts
- Choice of wetted parts to suit working media
- Electrical rating : 5A, 250 VAC; 0.2 A, 250 VDC (res.)
- Pressure ports: 1/4" BSPF

Some Applications : Works on opposed diaphragm principle, diaphragm seals can be coupled to this switch. Used in water treatment plants, bag filters, strainers, etc.

Range Selection Table

Range Code	Range bar (psi) ΔP	Approximate Maximum Differential* bar (psi)	Maximum Working Pressure bar (psi)
H01	0.1 - 1.0 (1.45 - 14.50)	0.15 (2.18)	12 (174.05)
H02	0.1 - 1.5 (1.45 - 21.76)	0.15 (2.18)	12 (174.05)
H03	0.2 - 2.6 (2.90 - 37.71)	0.2 (2.90)	12 (174.05)
H04	0.2 - 3.6 (2.90 - 52.21)	0.2 (2.90)	12 (174.05)
H07	0.5 - 7.0 (7.25 - 101.52)	0.2 (2.90)	12 (174.05)
H10	0.5 - 10.0 (7.25 - 145.04)	0.5 (7.25)	25 (362.6)
H15	1.0 - 15.0 (14.50 - 217.71)	0.5 (7.25)	25 (362.6)
H30	5.0 - 25.0 (72.52 - 362.6)	1.0 (14.50)	35 (507.63)

*Minimum differential increases with setpoint (Graphs available on request)

How to order DP series high range pressure difference switches

Group 1	Group 2	Group 3	Group 4	Group 5	Group 6
Model	Range Code	Range Scale	Pressure Housing	Diaphragm	Enclosure
DP - Pressure Difference Switch (Can be used for both side Positive Pressures Only)	H - High Pressure Range	U - Uncalibrated C - Calibrated	A - Aluminium B - Brass S - SS 316	0 - Neoprene 1 - Teflon	0 - IP 54
			for special wetted parts through chemical seals, please refer page 330, 331 & 332 and specify in text accordingly.		

eg. A pressure difference switch, high pressure range from 0.1-1.5 bar in calibrated style with brass pressure housing & a teflon diaphragm as wetted parts, with IP54 Enclosure shall be specified by

Group 1	Group 2	Group 3	Group 4	Group 5	Group 6
DP	H02	C	B	1	0

Please specify full model number to avoid ambiguity. If only the first two groups are specified while ordering, uncalibrated switches with standard wetted parts and enclosures will be supplied.

279 Bulletin No. KA121024

Product Selection Guide

High Range Pressure Switches



Page No. 246



Page No. 246



Page No. 248



Page No. 248

Model	MG	ME	MN	MA
Switch type	Single (High Pr.)	Adj. Diff. (High Pr.)	Single (High Pr.)	Adj. Diff. (High Pr.)
Differential type	Fixed	Adjustable	Fixed	Adjustable
Repeatability (% FSR)	± 1.5	± 1.5	± 1	± 1
Range covered	0.067 bar to 25 bar	0.1 bar to 25 bar	0.067 bar to 25 bar	0.1 bar to 25 bar
Enclosure Standard Optional	Pressed steel enclosures IP 40 as per IS 2147		Pr. diecast Al. (IP 54 as per IS 2147) Pr. diecast Al. (IP 65 as per IS 2147)	
W E T T E D P A R T S	sensing element Standard Optional	Diaphragm nylon reinforced neoprene diaphragm teflon		
	Pressure housing Standard Optional	Aluminium Brass/SS316		
	Other Wetted Parts	-		
	Optional wetted parts through chem. seal	-	SS316, Hastelloy B2, Hastelloy C4, Hastelloy C22, Hastelloy C276, Inconel Alloy 600, Monel Alloy 400, Monel Alloy K500, Nickel, Platinum, Tantalum, Titanium, Zirconium, Silver, PTFE	
Temp. of working medium	80°C maximum. For higher temperature, please use impulse tubing/chemical seals.			
Switching element	SPDT Snap action switch rated at 5A, 250 VAC, 0.2 A, 250 VDC resistive.			

Accessories can be supplied with most of the switches. Please consult sales office.

Product Selection Guide

Hydraulic Pressure Switches 2SPDT Hydraulic Pressure Switches



Page No. 250



Page No. 250



Page No. 252



Page No. 254

DN	DA	DJ	DK
Single (Hydr. Pr.)	Adj. Diff. (Hydr. Pr.)	2 SPDT (Hydr. Pr.)	2 SPDT (Hydr. Pr.)
Fixed	Adjustable	Diff. Fixed Stage Diff. Fixed	Diff. Fixed Stage Diff. Adjustable
± 1	± 1	± 2	± 2
3 bar to 400 bar		5 bar to 400 bar	5 bar to 100 bar
Pr. diecast Al. IP 65 as per IS 2147			
Piston EN8 SS			
Aluminium Brass			
Teflon, Viton, Brass, EN8			
SS316, Hastelloy B2, Hastelloy C4, Hastelloy C22, Hastelloy C276, Inconel Alloy 600, Monel Alloy 400, Monel Alloy K500, Nickel, Platinum, Tantalum, Titanium, Zirconium, Silver, PTFE			
80°C maximum. For higher temperature, please use impulse tubing/chemical seals.			
SPDT Snap action switch rated at 5A, 250 VAC, 0.2 A, 250 VDC resistive.			

Accessories can be supplied with most of the switches. Please consult sales office.

Product Selection Guide

Hygiene Range Pressure Switches

Hydraulic Pressure Switches



Page No. 256



Page No. 256



Page No. 258



Page No. 260

Model	MG	ME	HM (HIGH)	HM
Switch type	Single (Triclover)	Single (Triclover)	High range pr. switch	Hydraulic pr. switch
Differential type	Fixed	Adjustable	Fixed	Fixed
Repeatability (% FSR)	± 1.5		± 2	± 1
Range covered	0.2 bar to 15 bar		0.2 bar to 25 bar	3 bar to 400 bar
Enclosure Standard Optional	Pressed Steel Enclosure IP 40 as per IS 2147		Machined aluminium to IP 65	Machined aluminium to IP 65
WETTED PARTS	sensing element Standard Optional	Diaphragm SS316L		nylon reinforced neoprene diaphragm teflon
	Pressure housing Standard Optional	Triclover SS316L SS316L		Piston EN8 SS
	Other Wetted Parts			Aluminium Brass
	Optional wetted parts through chem. seal			Viton, MS/Brass, Nitrile
Temp. of working medium	80°C maximum. For higher temperature, please use impulse tubing/chemical seals.			
Switching element	SPDT Snap action switch rated at 5A, 250 VAC, 0.2 A, 250 VDC resistive.			

Accessories can be supplied with most of the switches. Please consult sales office.

Product Selection Guide

High Range Pressure Switches Hydraulic Pressure Switches Vacuum Switches

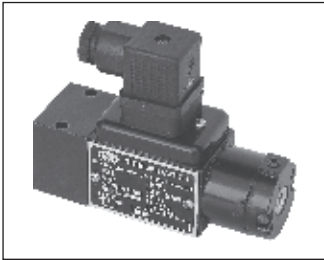

Page No. 262



Page No. 264



Page No. 266

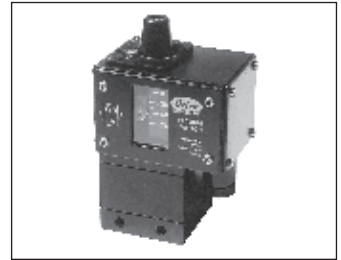

Page No. 268

HM 350	DT (HIGH)	DT	MN	
Hydraulic pr. switch	High range pr. switch	Hydraulic pr. switch	HI range vacuum sw.	
Fixed	Fixed	Fixed	Fixed	
± 2	± 2	± 2	± 2	
35 bar to 350 bar	1 bar to 15 bar	4 bar to 600 bar	760 to 100 mm Hg vac	
Pr. diecast Al. (IP 65 as per IS 2147)	Cast aluminium to IP 54		Pr. diecast Al. (IP 54 as per IS 2147) Pr. diecast Al. (IP 65 as per IS 2147)	
Piston EN8	Diaphragm nylon reinforced neoprene diaphragm	Piston EN8 SS	Diaphragm nylon reinforced neoprene diaphragm Teflon	
MS		Aluminium Brass	Aluminium Brass/SS316	
Viton, Teflon	EN8, Brass	EN8, Brass/SS, Viton	SS	
-	-	-	-	
80°C maximum. For higher temperature, please use impulse tubing/chemical seals.				
SPDT Snap action switch rated at 5A, 250 VAC, 0.2 A, 250 VDC resistive.				
<table border="1" style="margin-left: auto; margin-right: auto;"> <tr> <td>15 A, 250 VAC (res.) Optionally</td> </tr> </table>				15 A, 250 VAC (res.) Optionally
15 A, 250 VAC (res.) Optionally				

Accessories can be supplied with most of the switches. Please consult sales office.

Product Selection Guide

High Range Vacuum Switches

Low Range Pressure Switches

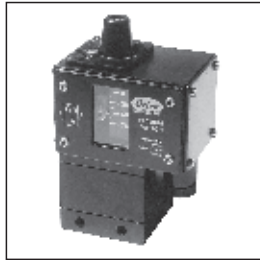

Page No. 268

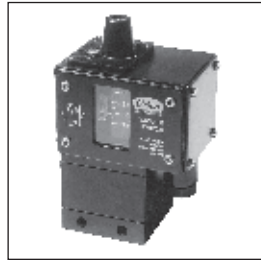

Page No. 270



Page No. 272



Page No. 272

Model	MA	VS1	MN	MA
Switch type	HI range vacuum sw.	HI range vacuum sw.	low range pr. sw.	low range pr. switch
Differential type	Adjustable	Fixed	Fixed	Adjustable
Repeatability (% FSR)	± 2	± 2	± 2	± 2
Range covered	760 to 100 mm Hg vac	760 to 100 mm Hg vac	20 to 2500 mm wg	
Enclosure Standard Optional	Pressure diecast Aluminium IP 54 as per IS 2147 IP 65 as per IS 2147			
sensing element Standard Optional	Diaphragm nylon reinforced neoprene diaphragm Teflon			
Pressure housing Standard Optional	Aluminium Brass/SS316		Aluminium SS316	
Other Wetted Parts	SS		SS, Nitrile	
Optional wetted parts through chem. seal	-		-	
Temp. of working medium	80°C maximum. For higher temperature, please use impulse tubing.			
Switching element	SPDT Snap action switch rated at 5A, 250 VAC, 0.2 A, 250 VDC resistive.		SPDT Snap action switch rated at 2A, 250 VAC, 0.2 A, 250 VDC resistive.	2A, 250 VAC, 0.2 A, 250 VDC resistive.

Accessories can be supplied with most of the switches. Please consult sales office.

Product Selection Guide

2 SPDT High Range Pressure Switches Pressure Difference Switches



Page No. 274



Page No. 276



Page No. 278

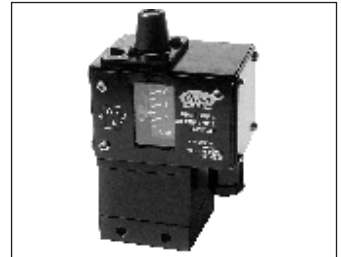

Page No. 280

MJ	MK	DP	PD
2 SPDT (HI Range Pr.)	2 SPDT (HI Range Pr.)	Pr. Difference switch	Pressure Difference Switch
Diff. Fixed, Stage Diff. Fixed	Diff. Fixed, Stage Diff. Adjustable	Fixed	Fixed
± 2	± 2	± 1	± 2
0.067 bar to 25 bar	0.1 bar to 25 bar	0.1 bar to 25 bar	0.1 bar to 3.6 bar
Pressure diecast Aluminium IP 54 as per IS 2147 IP 65 as per IS 2147			
diaphragm nylon reinforced neoprene teflon			
Aluminium Brass/SS 316			
			SS, Teflon
SS316, Hastelloy B2, Hastelloy C4, Hastelloy C22, Hastelloy C276, Inconel Alloy 600, Monel Alloy 400, Monel Alloy K500, Nickel, Platinum, Tantalum, Titanium, Zirconium, Silver, PTFE			
80°C maximum. For higher temperature, please use impulse tubing/chemical seals.			
SPDT Snap action switch TWO Microswitches rated at 5A, 250 VAC, 0.2 A, 250 VDC resistive.		5A, 250VAC, 0.2 A, 250VDC resistive.	

Accessories can be supplied with most of the switches. Please consult sales office.

Product Selection Guide

2 SPDT Pressure Difference Switches Low Range Pressure Difference Switches

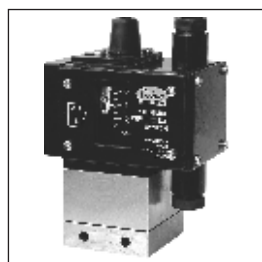

Page No. 282



Page No. 284



Page No. 286

Model	PJ	PD	PA
Switch type	2SPDT Pressure Diff.	Low range pr. diff.	Low range pr. diff.
Differential type	Fixed	Fixed	Adjustable
Repeatability (% FSR)	± 2	± 2	± 2
Range covered	0.1 bar to 3.6 bar	15 to 2500 mm wg	100 to 500 mm wg
Enclosure Standard Optional	Pressure diecast Aluminium IP 54 as per IS 2147 IP 65 as per IS 2147		
WETTED PARTS	sensing element Standard Optional	diaphragm nylon reinforced neoprene teflon	diaphragm nylon reinforced neoprene
	Pressure housing Standard Optional	Aluminium Brass/SS 316	MS SS316
	Other Wetted Parts	SS, Teflon	SS, Nitrile, Aluminium
	Optional wetted parts through chem. seal		
Temp. of working medium	80°C maximum. For higher temperature, please use impulse tubing/chemical seals.		
Switching element	5A, 250VAC, 0.2 A, 250VDC resistive. TWO Microswitches of above rating	SPDT Snap action switch rated at 5A, 250 VAC, 0.2 A, 250 VDC resistive.	

Accessories can be supplied with most of the switches. Please consult sales office.

VS1 VACUUM SWITCHES



PRESSURE CAPSULE DETAILS

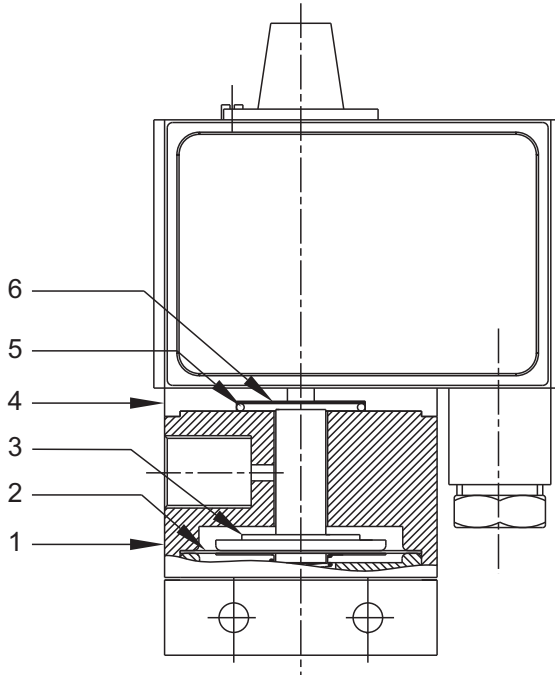

- | No. | Description |
|-----|-------------------------------------|
| 1. | <i>Disc (Aluminium)</i> |
| 2. | <i>Diaphragm (Teflon®)</i> |
| 3. | <i>Plunger (SS 316)</i> |
| 4. | Junction Plate |
| 5. | <i>Sealing 'O' ring (Teflon®)</i> |
| 6. | <i>Sealing diaphragms (Teflon®)</i> |

Note : *wetted parts* are mentioned in italics.

INSTALLATION DRAWING

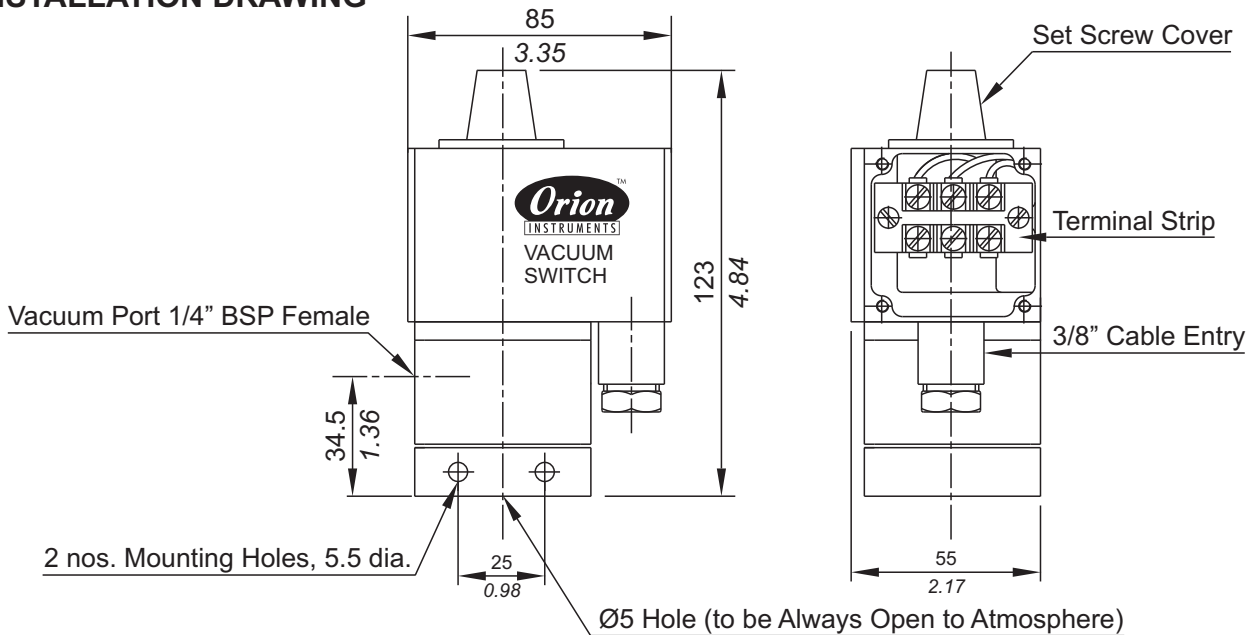

APPROX. DIMENSIONS IN $\frac{\text{mm}}{\text{inches}}$

VACUUM SWITCHES VS1

GENERAL INFORMATION :

VS1 series vacuum switches are housed in pressure die cast aluminium powder coated enclosure and are recommended for panel mounting or outdoor service. The repeat accuracy is better than $\pm 2\%$ FSR. A 3/8" cable entry is provided for cables and a terminal strip suitable for wired ends is provided inside the enclosure. Pressure port is 1/4" BSPF standard.

FEATURES :

- Compact
- Separate chamber for working parts
- Electrical rating : 5A, 250VAC; 0.2A, 250 VDC
- Pressure port : 1/4" BSPF

Some Applications : Vacuum Systems requiring low on-off differential.

RANGE SELECTION TABLE

Range code	Range vacuum (falling) mm Hg ("Hg)	*Approximate Maximum Differential (Fixed) mm Hg ("Hg)	Maximum Working Pressure bar (psi)
V00	† 760 - 100 (29.92 - 3.94)	10 (0.39)	12 (174.05)

* Minimum differential increases with setpoint (Graphs available on request)

† Typical values achieved at sea level, total vacuum that can be achieved varies mainly with altitude.

HOW TO ORDER VS1 SERIES VACUUM SWITCHES

Group 1	Group 2	Group 3	Group 4	Group 5	Group 6
Model	Range Code	Range Scale	Disc	Diaphragm	Enclosure
VS1 - Fixed differential Vacuum Switch	-	-	-	-	-

Eg. A fixed differential vacuum switch, high range from 760 mm Hg vac. To 100 mm Hg vac. shall be specified by

Group 1	Group 2	Group 3	Group 4	Group 5	Group 6
VS1	-	-	-	-	-

Please specify full model number to avoid ambiguity. If only the first two groups are specified while ordering, uncalibrated switches with standard wetted parts and enclosures will be supplied.

Introduction

These are the items which are used in most general purpose applications. These switches cannot be configured and are generally intended for stock and sell.

As such, many of them are picked from all the above categories, and can be ordered by part numbers. These will generally have minimum order quantities, and would be available off the shelf.

APPLICATIONS

- Power Generation
- Burners and Furnaces
- Glass and Metal Industries
- Chemical Industries
- Steel Industry
- Hydraulic, Steam and Gas Turbines
- Boilers & Compressors
- Machine tools
- Water treatment
- Sugar and Paper Mills
- Fire protection
- Surgical gas, Breweries, Milk industries
- Tyre Industry

PRODUCT SPECIFICATIONS:

- Storage temperature : Atmospheric temperature
- Operating ambient temperature : - 20° C to + 60° C
- Media temperature : for rubber diaphragms 80° C max
- Can be offered for higher temperatures with other capsule combinations
- Setpoint repeatability : $\pm 1\%$ of FSR
- Enclosure : IP rating varies as per model selected
- Switch output : SPDT
- Process connection : $\frac{1}{4}$ " BSP standard,
- Approximate weight : 1 kg

FEATURES

- Low cost
- Easily available
- Reliable accurate microswitches for long life switching
- Customized arrangements for switching values on request
- Easy safe wiring options
- Accuracy $\pm 1\%$ FSR
- Warranty : 2 years

*Accuracy changes with switch configuration

ACCESSORIES

Following accessories can be provided with pressure switches to make it suitable for any particular application.

- | | |
|--|---|
| Flameproof enclosures | syphons |
| Chemical seals (or diaphragm seals) | manifolds |
| adaptors to suit customer's process connection | pipe mounting brackets |
| switch savers | mounting plates to suit other makes on the market |
| impulse tubes | snubbers |
| | tag plates (to display tag no. and identify the instrument) |

Installation drawings of most common and fast moving accessories are given. The wetted parts, wherever applicable, are not specified due to the extreme variety available.

MOUNTING PLATE

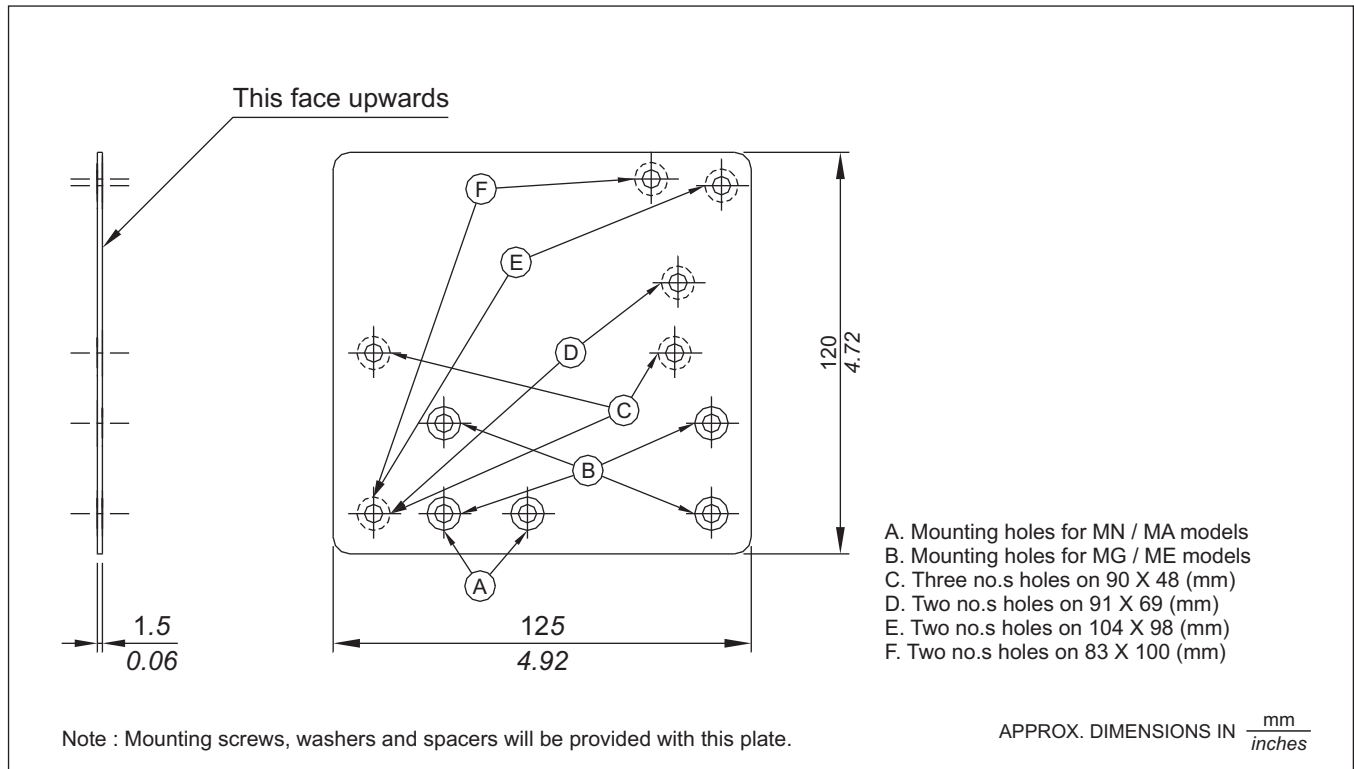

ACCESSORIES

Gauge Saver



A OPP 1 = Set Pressure: 0.6 to 2.0 bar
 A OPP 2 = Set Pressure: 2.5 to 200 bar

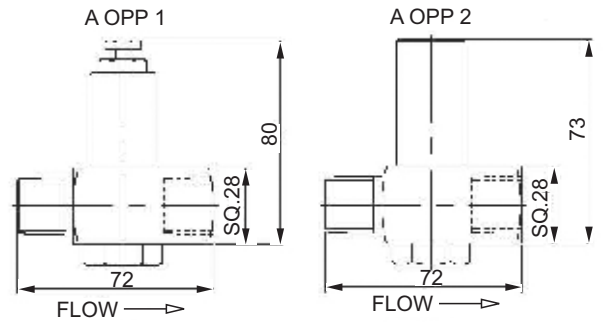

2 Valve Manifold

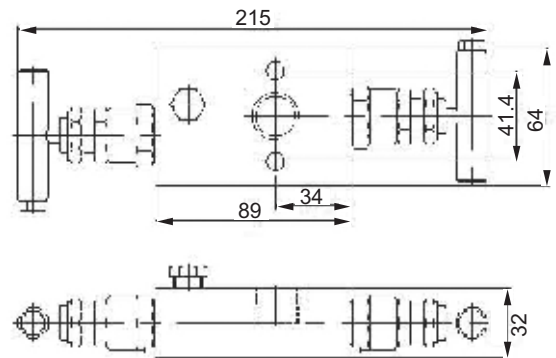

3 Valve Manifold

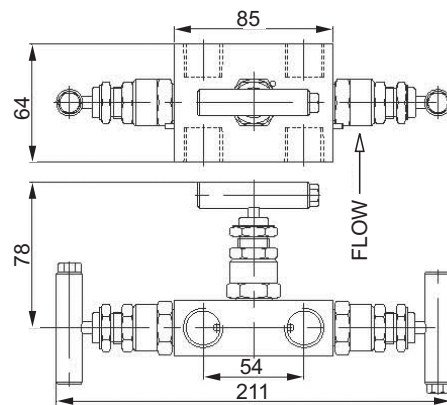

Snubber



SIZE	A	B
1/4"NPT	55	25
3/8"NPT	55	25
1/2"NPT	63	28
G1/2"	63	28

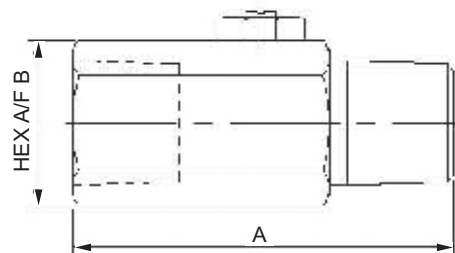

ACCESSORIES

CHEMICAL SEALS (DIAPHRAGM SEALS):

General description:

Diaphragm seals are partitions used with pressure switches which prevent the measured medium from entering the pressure capsule of the pressure switch. Diaphragm seals solve many problems encountered in sensing, which are otherwise impossible to solve with only pressure switches. Some of the examples are:

- protection of pressure switch from aggressive, highly viscous solidifying or crystallizing measured media
- protection from high measured medium temperatures or fluctuations in temperature
- protection from vibrations by coupling via capillaries
- dead zone free sensing arrangements for particular hygienic applications
- use of special materials or surface coatings of the wetted parts for special applications.

CAUTION: Pressure switch and diaphragm seal are always a closed system and should not be separated by unauthorised persons.

When the pressure switch is to be kept away from undesirable temperatures or vibrations, a capillary can be used to connect the pressure switch and the diaphragm seal. Capillaries also have a throttling effect which is often desirable in pulsating process pressures. During setpoint adjustment, the weight of the liquid column between the diaphragm seal and the pressure switch needs to be taken into consideration, if they are mounted at different elevations.

Depending on the application, a variety of media with different properties are used as transmission liquids. For most of the general applications, silicon oil can be used. For food industries, a transmission liquid compatible with the process needs to be used.

A variety of chemical seals can be supplied with pressure switches and only the most commonly used arrangements / assemblies are shown here.

In most of the cases, the common wetted parts and diaphragms are of SS316. Alternate wetted materials that can be provided are:

- HASTELLOY B2
- HASTELLOY C4
- HASTELLOY C22
- HASTELLOY C276
- INCONEL ALLOY 600
- MONELALLOY 400
- MONELALLOY K500
- NICKEL
- PLATINUM
- TANTALUM
- TITANIUM
- ZIRCONIUM
- SILVER
- PTFE

The on - off differentials of pressure switches fitted with chemical seals are likely to be higher than those mentioned in the catalogue. There is also a possibility of time lag (for sensing) being introduced, depending on the length of the tubing between the pressure switch and the seal.

While ordering, customer's are requested to specify all the process parameters including ambient conditions, operating conditions, the process to be sensed and response times allowable, temperature of the seal under sensing conditions and temperature outside the measuring / sensing sequences (e.g as in rinsing sequences) so that a proper sealing system can be suggested.

ACCESSORIES

STANDARD CHEMICAL SEAL SUITABLE FOR THREADED CONNECTION : (Type A)

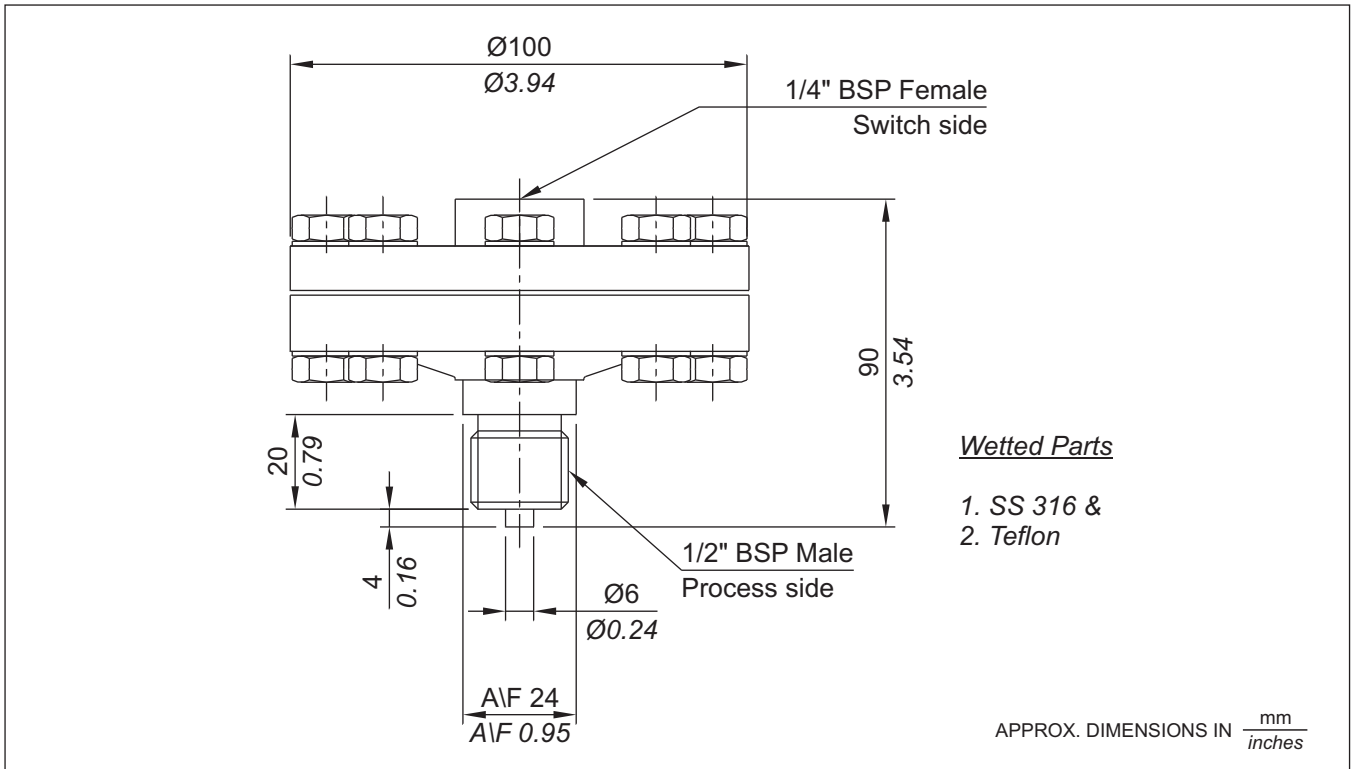

CHEMICAL SEAL SUITABLE FOR VARIABLE FLANGED CONNECTION : (Type B)

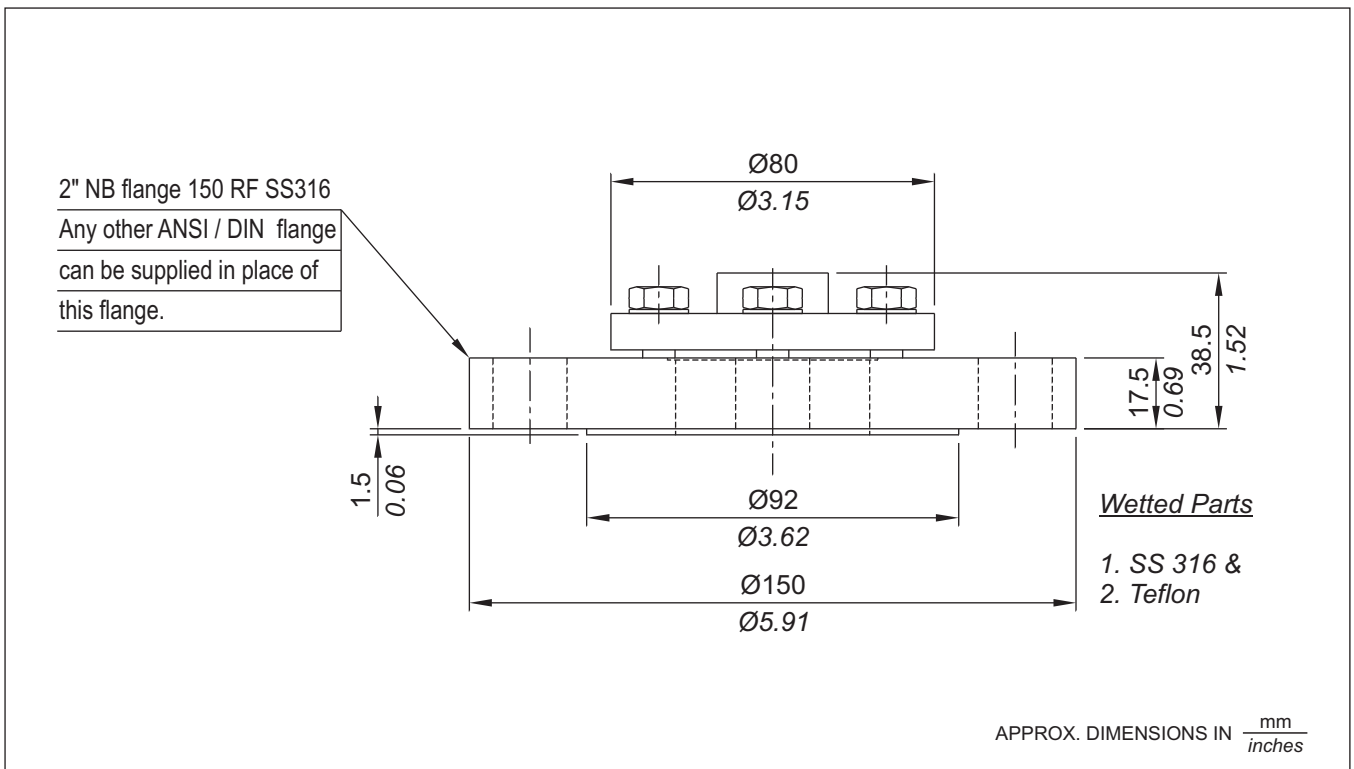

ACCESSORIES

FLUSH TYPE CHEMICAL SEAL (Type C)

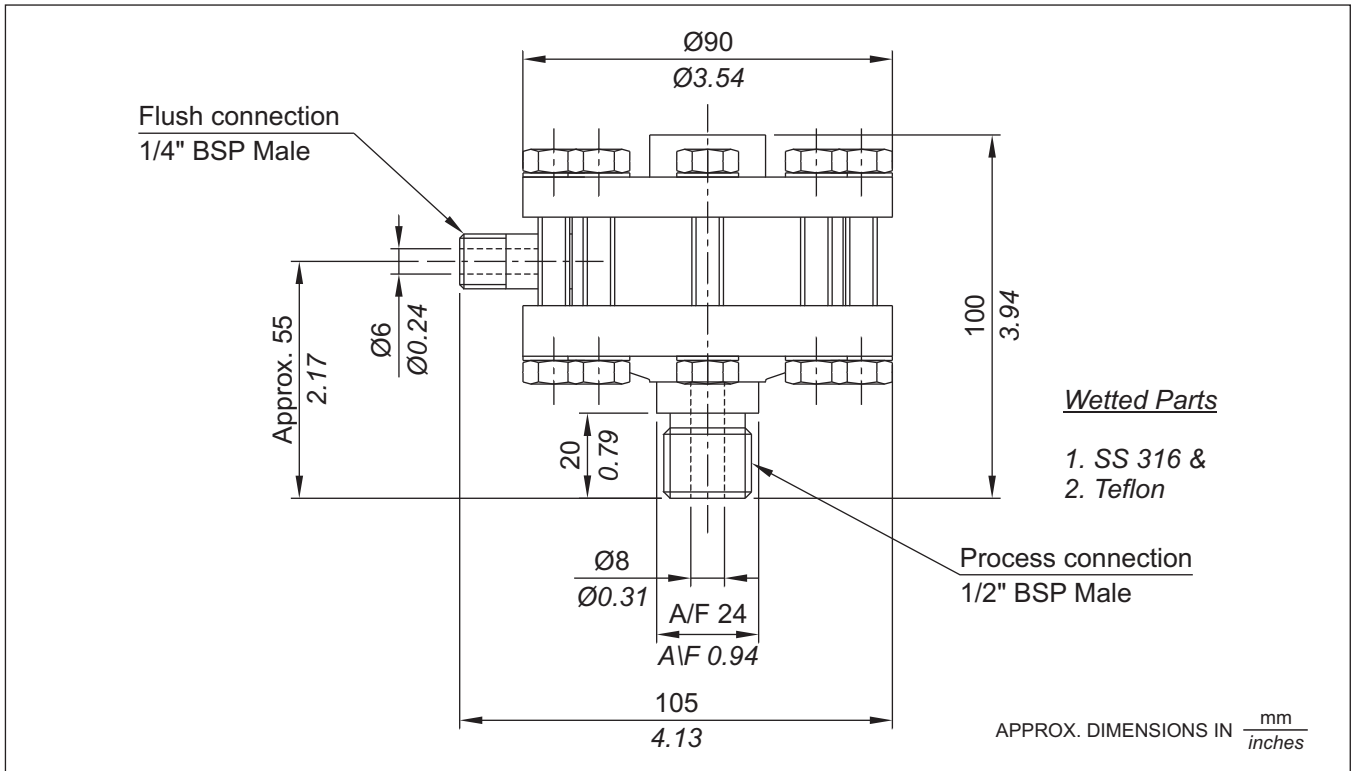

FULL WELDED CHEMICAL SEAL (Type D)

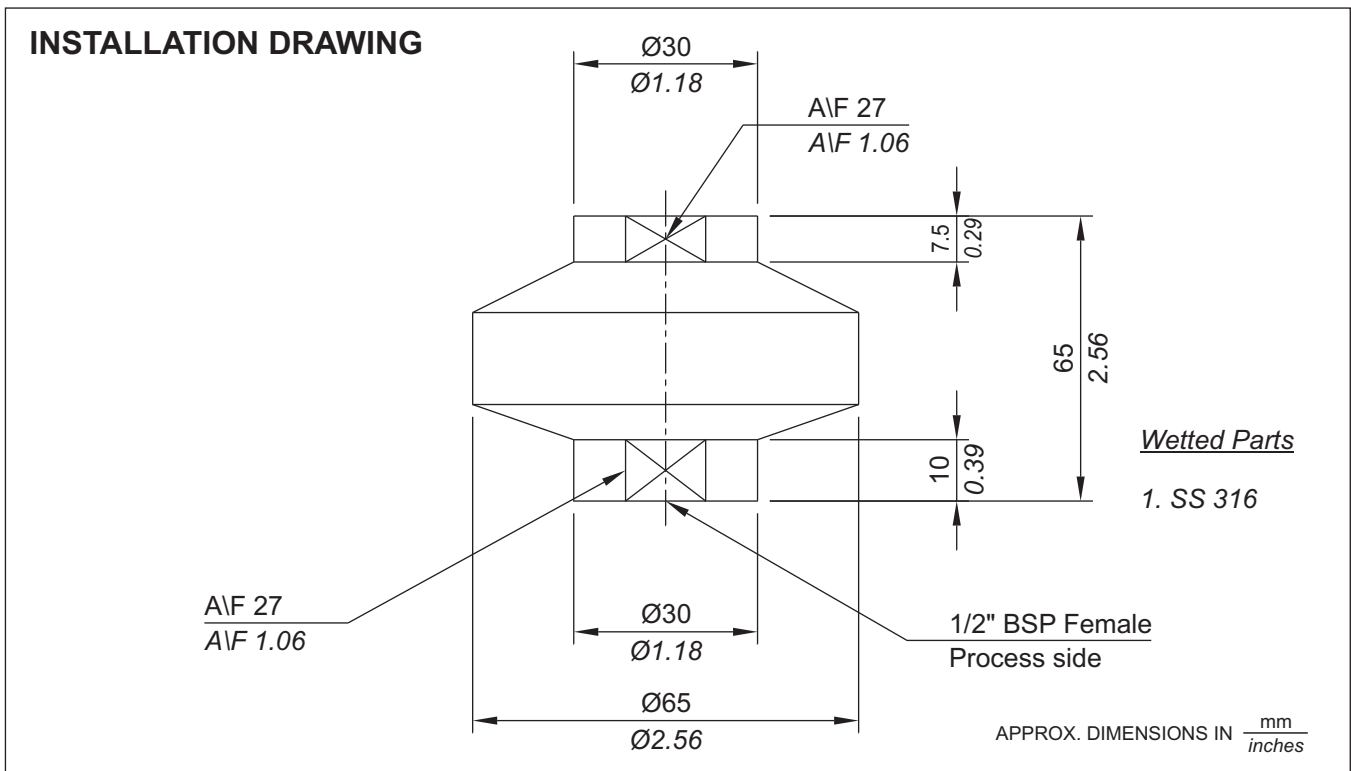

GENERAL SPECIFICATIONS AND APPLICATION NOTES

1. All the pressure switches contained in this catalogue are gauge pressure switches.
2. Pressure switches are switching instruments and not measuring ones. As such, the word "calibration" is used for the markings made on the scale to indicate the approximate setpoint of the pressure switch. No "calibration certificate" for this indication can be given in the proper sense of the word. However, the pressure switches can be supplied preset at user specified setpoints, provided the setpoints are indicated during the ordering stage itself.
3. Process temperature : can be 80 deg. C maximum. A pressure switch being a dead end, is not subjected to continuous process temperature(as in case of flow). As such, a proper length of impulse tubing of proper material (or chemical seals with adequate tubing) will substantially bring down the temperature, well within the specified limits. Normal pressure switches (without any modifications) have been used with working media having a temperature of upto 350 deg. C, only by employing an additional impulse tube.
4. Ambient temperature: can be from -10 deg. C to 60 deg. C for most of the standard pressure switches. Care should be taken that no icing occurs inside the enclosure where the atmospheres are humid, when pressure switches are used in subzero ambient temperature areas. Pressure switches for use in wider ambient temperatures can be developed should your application fall in such areas. If the process is likely to freeze / crystallize / solidify within this ambient range, chemical seals should be used alongwith the pressure switches.
5. All the pressure switches are tested on kerosene / air prior to despatch. For applications involving food grade material / oxygen service or processes not compatible with kerosene, such a note should be specifically made while ordering, so that pressure switches are tested accordingly.
6. All data published is under standard test conditions. Following conditions generally apply for Laboratory Evaluation tests:

Temperature	:	Ambient room temperature (21 °C)
Humidity	:	Ambient (50%)
Proof pressure	:	1.5 times maximum working pressure
Cycling rate	:	30 cycles/minute
Pressure rise	:	compatible with above cycling rate (maximum)
Life in no. of cycles	:	100,000 minimum

The life and characteristics of pressure switches can be affected by temperature, humidity, airborne contamination, vibration and frequency of operation of the pressure switches. For specific switch selection, customers are requested to evaluate switch performance under actual application conditions or by simulating all the extreme application conditions and requirements. Laboratory Evaluation test data can never substitute customer's own product evaluation.

The life of the pressure switches can be increased by incorporating changes in design or by substituting certain components. Customers are requested to contact our sales office for any such specific requirements.

DEFINITIONS & TERMINOLOGY FOR PRESSURE ACTUATED SWITCHES

Pressure Switch:- A pressure switch is an instrument that automatically senses a change in pressure and opens or closes an electrical switching element when a pre-determined pressure point is reached.

Pressure sensing element:- A pressure sensing element is the portion of the pressure switch that transmits motion due to change in pressure.

Electrical switching element:- The electrical switching element in a pressure switch opens or closes an electrical circuit in response to the actuating force it receives from the pressure sensing element. Orion pressure switches are fitted with single pole double throw (SPDT) snap action switch(es) as electrical switching element (s) for maximum reliability.

Normally open switching element:- No current can flow through the switching element until the switch is actuated.

Normally closed switching element:- Current flows through the switching element until the switch is actuated.

Set Point:- The set point is expressed in terms of exact pressure at which the snap-action switch is actuated to either open or close the electrical circuit (depending on how the switch is wired).

Differential (Dead band, Hysteresis):- Differential is the difference between the actuation point and the deactuation point, e.g. if a pressure switch is set to operate at 5 bar on increasing pressure, the switch will close when the pressure rises to that point. As the pressure drops to, say, 4.8 bar the switch may open (this is the deactuation point). The differential of this switch is then 0.2 bar, the difference between the set point of 5 bar and deactuation point of 4.8 bar. Differential is sometimes referred to as "deadband" or "hysteresis".

Set Point in relation to increasing pressure & decreasing pressure:- A pressure switch may be set to actuate at any desired point on rising pressure or falling pressure. The former is described as "set to actuate on increasing (or rising) pressure" & the latter as "set to actuate on decreasing (or falling) pressure". The preferred actuation must be specified clearly on orders for pressure switches that are to be factory set.

Range :- The span within which the set point of a pressure-actuated switch may be adjusted.

Proof Pressure :- Proof pressure is the highest pressure to which a switch may be subjected without permanent damage.

Maximum working pressure (MWP) :- The nominal pressure level that a system will operate at, including workload.

Differential pressure :- The difference between a reference pressure and a variable pressure.

Wetted parts :- The parts which come in contact with the working medium.

HOW TO SELECT A PRESSURE SWITCH FOR YOUR APPLICATION

Following are the general guidelines which should help you arrive at a proper selection of a pressure switch for your application.

Step 1.

Service life of the switch. Expected service life is the first consideration to be made in selecting a pressure switch, regardless of sensitivity or pressure desired. A second consideration in choosing a pressure switch is the speed of cycling, regardless of the service life. A sensing element made of metal sheets is likely to fatigue at cycling speeds above 20 cycles per minute and is not recommended for service life of more than 1 million cycles. Orion and Parus pressure switches use nylon reinforced rubber or piston as a sensing element and have been tested at a cycling frequency of 30 cycles / minute for more than a million cycles. The working medium to be controlled must be considered and to simplify selection, wetted parts are indicated on the catalogue pages.

Step 2.

Proof pressure - Choice of type of pressure switch must also be governed by the highest pressure to which it will ever be subjected. The highest pressure in the system including surges, should not be more than the proof pressure of the switch. It must be remembered that, though there are surges in the system, a pressure gauge may register a constant reading, the surges being dampened out by the orifice in the gauge.

Step 3.

Function of the switch. Three types of Orion pressure switches, based on function, are described below, a) Single setting pressure switches : They sense a single pressure source and open or close a single electrical circuit by means of a snap action electrical switch. b) Pressure difference switches : They sense a change in relationship between two pressures and open or close a single electrical circuit by means of a snap action electrical switch. c) Adjustable differential pressure switches: They sense two pressure limits, within a desired adjustable range, from a single pressure source and open or close a single electrical circuit by means of a snap action electrical switch.

Step 4.

Selection of adjustable range. The range should be selected such that the setpoint lies as close as possible to the middle of the total adjustable range. This will ensure the most favourable combination of accuracy and life.

Step 5.

Working medium. The working medium should be compatible with the wetted parts. For easier selection, the wetted parts are given in the catalogue pages. The maximum temperature of the working medium is also important. A pressure switch, being a dead end, is not subjected to continuous temperature. If the temperature of the working medium exceeds 80 deg. C, an impulse tubing of appropriate length should be used between the process connection and pressure port of the switch. Where the working medium is likely to freeze at the sensing element, a diaphragm seal (chemical seal) with appropriate wetted parts should be used. In case of excessive temperature or mounting the pressure switch remotely, pressure switches can also be supplied with remote seals. The filling medium has to be compatible with the working medium, and needs to be specified while ordering. (Specially in case of food related industries / processes)

Step 6.

Environment. The environment in which the pressure switch will operate is very important. Orion pressure switches can be supplied in weatherproof enclosures for outdoor service. For use of pressure switches in hazardous areas Orion pressure switches can be supplied in flameproof enclosures.